

JANOME ELECTRO PRESS

JP-104	JP-204	JP-504	JP-1004
JP-1504	JP-3004	JP-5004	
JPH-104	JPH-204	JPH-504	JPH-1004
JPH-1504	JPH-3004	JPH-5004	
JPU-104	JPU-204	JPU-504	JPU-1004
JPU-1504	JPU-3004	JPU-5004	JPU-8004

Operation Manual

<Specifications>

Thank you for purchasing the Electro Press.

*Read this manual thoroughly in order to properly use this machine.

Be sure to read "For Your Safety" before you use the machine. It will protect you from possible dangers during operation.

*After having read this manual, keep it in a handy place so that you or the operator can refer to it whenever necessary.

JANOME

FOR YOUR SAFETY

Safety Precautions



The precautions stated in this manual are provided for the customer to make the best use of this product safely, and to provide preventive measures against injury to the customer or damage to property.

• • • • • **Be sure to follow the instructions** • • • • •

Various symbols are used in this manual. Please read the following explanations to understand what each symbol stands for.











Symbols indicating the Degree of Damage or Danger

The following symbols indicate the degree of damage or danger which may be incurred if you neglect the safety notes.

	Warnings These “Warnings” indicate the possibility of death or serious injury.
	Cautions These “Cautions” indicate the possibility of accidental injury or damage to property.

Symbols indicating the type of Danger and Preventive Measures

The following symbols indicate the type of safety measure that should be taken.

	Indicates the type of safety measure that should be taken.
	Take care. (General caution)
	Indicates prohibition.
	Never do this. (general prohibition)
	Do not disassemble, modify or repair.
	Do not touch. (contact prohibition)
	Indicates necessity
	Be sure to follow instructions.
	Be sure to unplug the power supply from wall outlet.
	Be sure to check grounding.

FOR YOUR SAFETY

Warnings



Do not leave the unit plugged in (power cord and connectors) when it is not in use for long periods of time. Dust can cause fire.

Be sure to shut off the power supply before removing the power cord.



Regularly replace the built-in battery (optional) in the body or control box. It is preferable to replace it every 3 years.

Failure to do so may cause malfunction or defect.



Keep the emergency stop switch within reach of an operator while teaching and running the machine.

Failure to do so is dangerous because the machine cannot be stopped quickly and safely.



Regularly check that the I/O-S circuits and emergency stop switch work properly.

Failure to do so is dangerous because the machine cannot be stopped quickly and safely.



Check the mounting screws regularly so that they are always firmly tightened.

Loose screws may cause injury or damage.



Power the unit only with the rated voltage.

Excessive voltage can cause fire or malfunction of the unit.



Do not sprinkle water or oil on the unit, control box, or its cable.

Contact with water can cause electric shock, fire, or malfunction of the unit. IP Protection Rating is IP40.



A person entering the machine's operation area may be injured.

Put up a "No Entry" or "No Operating" warning sign in a clearly visible position near the machine.

FOR YOUR SAFETY

INSTALLATION

Warnings



Install an interlock as a safeguard that triggers an emergency stop when it is activated using the I/O-S connector included in the package.

<Example>

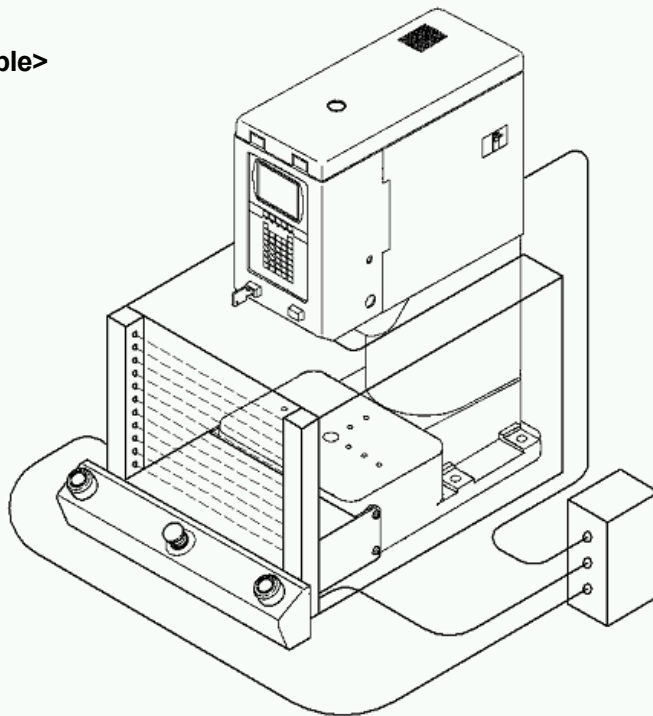

Use protective wear (helmet, protective gloves, protective glasses and protective footwear) when installing the machine.



Place the machine in a well-ventilated area for the health and safety of the operator.



Place the machine on a suitable flat surface that can support its weight and do not cover the cooling fan vent on the top of a stand-alone and head type.
An insufficient or unstable area can cause the machine to fall, overturn, breakdown or overheat.

FOR YOUR SAFETY

Warnings



Confirm that the unit is properly grounded.

Power supply earth should be connected complying with Type D grounding.
(under 100 Ω of resistance.)

Insufficient grounding can cause electric shock, fire or malfunction.



Plug the power cord into the wall outlet firmly.

Incomplete insertion into the wall outlet heats the plug and can cause fire.
Check that the plug is not covered with dust.

Be sure to shut off the power supply before connecting the power cord



Do not attempt to disassemble or modify the machine.

Disassembly or modification may cause electric shock, fire or malfunction.



Be sure to use within the voltage range indicated on the unit.

Failure to do so may cause electric shock or fire.



Do not use the unit near inflammable or corrosive gas.

If leaked gas accumulates around the unit, it can cause fire.

IP Protection Rating is IP40.



Turn off the unit before inserting and removing cables.

Failure to do so may result in electric shock, fire, or malfunction of the unit.

IP Protection Rating is "IP40."



Use the machine in an environment between 0 to 40 degrees centigrade with a humidity of 20 to 95 percent without condensation.

Use outside use conditions may result in malfunction.

IP Protection Rating is "IP40."



Keep the emergency stop switch within reach of an operator while teaching and running the machine.

Failure to do so may cause danger since the machine cannot be stopped immediately and safely.

FOR YOUR SAFETY

Warnings



Use the machine in an environment where no electric noise is present.



Attach an eyebolt and use a crane or other equipment to transport the machine.

Failure to do so may result in malfunction or defect.



Do not bump or jar the machine while it is being transported or installed.

This can cause defects.



Use the machine in an environment where it is not exposed to direct sunlight.

Direct sunlight may cause malfunction or defect.



Be sure to confirm that jigs such as the electric screwdriver unit, etc. are properly connected.

Failure to do so may result in injury or defect.



Be sure to check the wiring to the main unit.

Improper wiring may cause malfunction or defect.



Be sure to shut off the power supply before plugging the power cord.



Place the control box on a flat surface more than 80 cm above the floor so that it is easier to operate it.



The installation mount should be steel. **For the stand-alone type, it should be able to support the machine's weight. For the head and unit types, it is able to support the machine's weight and pressing capacity.**



Use the machine in an environment that is not dusty or damp.

Dust and dampness may cause failure or malfunction.

FOR YOUR SAFETY

WORKING ENVIRONMENT

Warnings



When you lubricate or inspect the unit, unplug the power cord from the outlet.

Failure to do so may result in electric shock or injury.

Be sure to shut off the power supply before removing the power cord.



During operation, always have the emergency stop switch within the operator's reach.

For the operator's safety, the emergency stop switch is necessary to make a quick and safe stop in an emergency.



Always be aware of the machine's movement, even in the teaching mode.

Special attention will protect the operator from injury.

FOR YOUR SAFETY

DURING OPERATION

Warnings



When starting the machine, check that **no object will interfere with the machine's operation.**



Under no circumstances should you go inside the working area or place your hands or head inside the working area while the machine is operating.



If anything unusual (e.g. a burning smell) occurs, stop operation and unplug the cable immediately. Contact your dealer or the office listed on the last page of this manual.

Continuous use without repair can cause electric shock, fire, or breakdown of the unit.



During teaching, tests, and actual operation, always have the Emergency stop switch within the operator's reach.

For the operator's safety, the emergency stop switch is necessary to make a quick and safe stop in an emergency.

PREFACE

The operation manual for the JANOME Electro Press consists of the following volumes. “For Your Safety” is also provided so that the customer can make the best use of this product safely. This section includes preventive measures that can be taken against injury to the customer or damage to property. Please be sure to read “For Your Safety” before using this product.

Setup	This volume explains how to set up the Electro Press. * For those who have received training in Electro Press safety and installation.
Maintenance	This volume explains Electro Press maintenance. * For those who have received training in Electro Press safety and installation.
Teaching and Operation	This volume lists part names and data structure as well as providing the basic knowledge necessary to operate the Electro Press.
Operation	This volume explains how to operate the Electro Press.
Specifications	This volume provides comprehensive specifications, including mechanical and electrical requirements.

Note: The product specifications in these volumes may differ from those of the machine you have received due to a product upgrade.

Please be sure to follow the instructions described in these volumes. Proper use of the robot will ensure continued functionality and high performance. These volumes are based on the standard application. Menu items may vary depending on the model.



Be sure to shut off the power supply before plugging in the power cord.



BE SURE TO MAKE A PROPER GROUNDING WHEN YOU INSTALL THE MACHINE.



Be sure to save data whenever it is added or modified. **Otherwise, changes will not be saved if the power to the robot is cut off.**

CONTENTS

FOR YOUR SAFETY	i
PREFACE	viii
CONTENTS	ix
1. LINEUP	1
1-1 Model Identification	2
2. EXTERNAL DIMENSIONS	3
2-1 JP-104/JP-204 Stand-Alone Type	3
2-2 JP-504/JP-1004/JP-1504 Stand-Alone Type	4
2-3 JP-3004/JP-5004 Stand-Alone Type	5
2-4 JPH-104/JPH-204 Head Type	6
2-5 JPH-504/JPH-1004/JPH-1504 Head Type	7
2-6 JPH-3004/JPH-5004 Head Type	8
2-7 JPU-104/JPU-204 Unit Type	9
2-8 JPU-504/JPU-1004 Unit Type	10
2-9 JPU-1504 Unit Type	11
2-10 JPU-3004/JPU-5004 Unit Type	12
2-11 JPU-8004 Unit Type	13
2-12 Control Box (JPB-104 to JPB-1504)	14
2-13 Control Box (JPB-3004 to JPB-8004)	15
2-14 Teaching Pendant	16
2-15 Monitor Box (Optional)	17
2-16 Switch Box (Optional)	18
3. I/O-SYS	19
3-1 Connector	19
3-2 System Input/Output Functions of I/O-SYS Signals	20
3-3 I/O-SYS Circuit Diagram	24
3-4 I/O-SYS Input Signal (Sink Input)	25
3-5 I/O-SYS Output Signal (Sink Output)	26
3-6 I/O-SYS Output Capacity (Sink Output)	26
3-7 I/O-SYS Input Signal (Source Input)	27
3-8 I/O-SYS Output Signal (Source Output)	28
3-9 I/O-SYS Output Capacity (Source Output)	28
3-10 Switching I/O-SYS Power Supply	29
3-11 I/O-SYS Timing Chart	30
3-12 I/O-SYS Connection	42
3-13 I/O-SYS Cable (Optional)	44
4. I/O-1 (Optional)	45
4-1 I/O-1 Connector	45
4-2 Function Assignment	46
4-3 I/O-1 Input Signal (Sink Input)	47
4-4 I/O-1 Output Signal (Sink Output)	48
4-5 I/O-1 Output Capacity (Sink Output)	48
4-6 I/O-1 Circuit Diagram (Sink Input/Output)	49
4-7 I/O-1 Input Signal (Source Input)	50
4-8 I/O-1 Output Signal (Source Output)	51
4-9 I/O-1 Output Capacity (Source Output)	51
4-10 I/O-1 Circuit Diagram (Source Input/Output)	52
4-11 Switching I/O-1 Power Supply	53

5. I/O-S _____	54
5-1 I/O-S Connector _____	54
5-2 I/O-S Pin Assignment _____	55
6. COM _____	58
6-1 COM Connector _____	58
6-2 Pin Connection _____	59
7. SWITCH BOX CONNECTOR _____	60
7-1 Switch Box Connector _____	60
7-2 Switch Box Connector Assignment _____	61
8. TEACHING PENDANT CONNECTOR _____	62
8-1 Teaching Pendant Connector _____	62
8-2 Pin Assignment of Teaching Pendant Connector _____	63
8-3 Teaching Pendant Connector Circuit Diagram _____	64
9. LOAD CELL OUTPUT (OPTIONAL) _____	65
9-1 Load Cell Output Connector _____	65
9-2 Pin Assignment of Load Cell Output _____	66
10. ENCODER OUTPUT (OPTIONAL) _____	67
10-1 Encoder Output Connector _____	67
10-2 Pin Assignment of Encoder Output _____	68
11. MENU LIST _____	69
12. SPECIFICATIONS _____	72
12-1 Functions _____	72
12-1-1 JP/JPH/JPU-104 and 204 _____	72
12-1-2 JP/JPH/JPU-504 and 1004 _____	73
12-1-3 JP/JPH/JPU-1504 _____	74
12-1-4 JP/JPH/JPU-3004 and 5004 _____	75
12-1-5 JPU-8004 _____	76
APPENDIX. GENERAL EXTERNAL I/O TIMING CHART _____	78

1. LINEUP

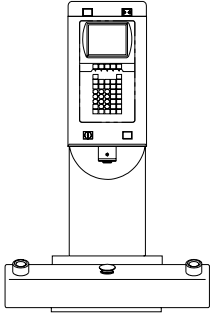
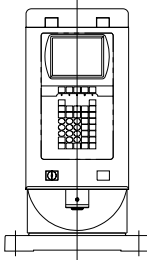
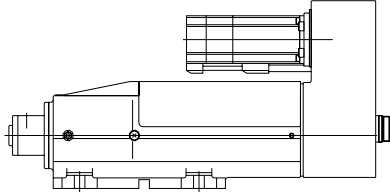
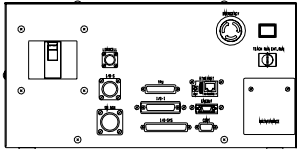
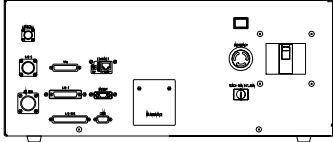
	Appearance	Model
Stand-Alone Type		JP-104
		JP-204
		JP-504
		JP-1004
		JP-1504
		JP-3004
		JP-5004
Head Type		JPH-104
		JPH-204
		JPH-504
		JPH-1004
		JPH-1504
		JPH-3004
		JPH-5004
Unit Type		JPU-104
		JPU-204
		JPU-504
		JPU-1004
		JPU-1504
		JPU-3004
		JPU-5004
		JPU-8004
Control Box		JPB-104
		JPB-204
		JPB-504
		JPB-1004
		JPB-1504
		JPB-3004
		JPB-5004
		JPB-8004U

1-1 Model Identification

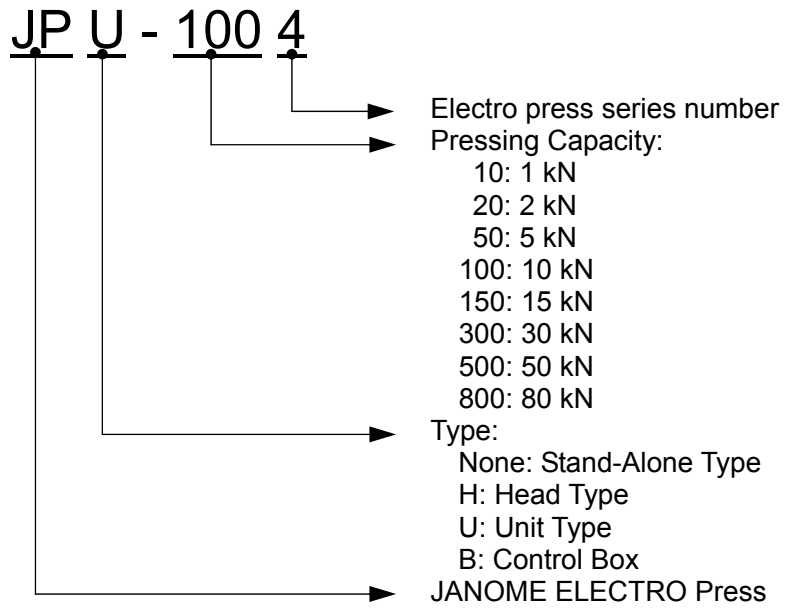

2. EXTERNAL DIMENSIONS

2-1 JP-104/JP-204 Stand-Alone Type

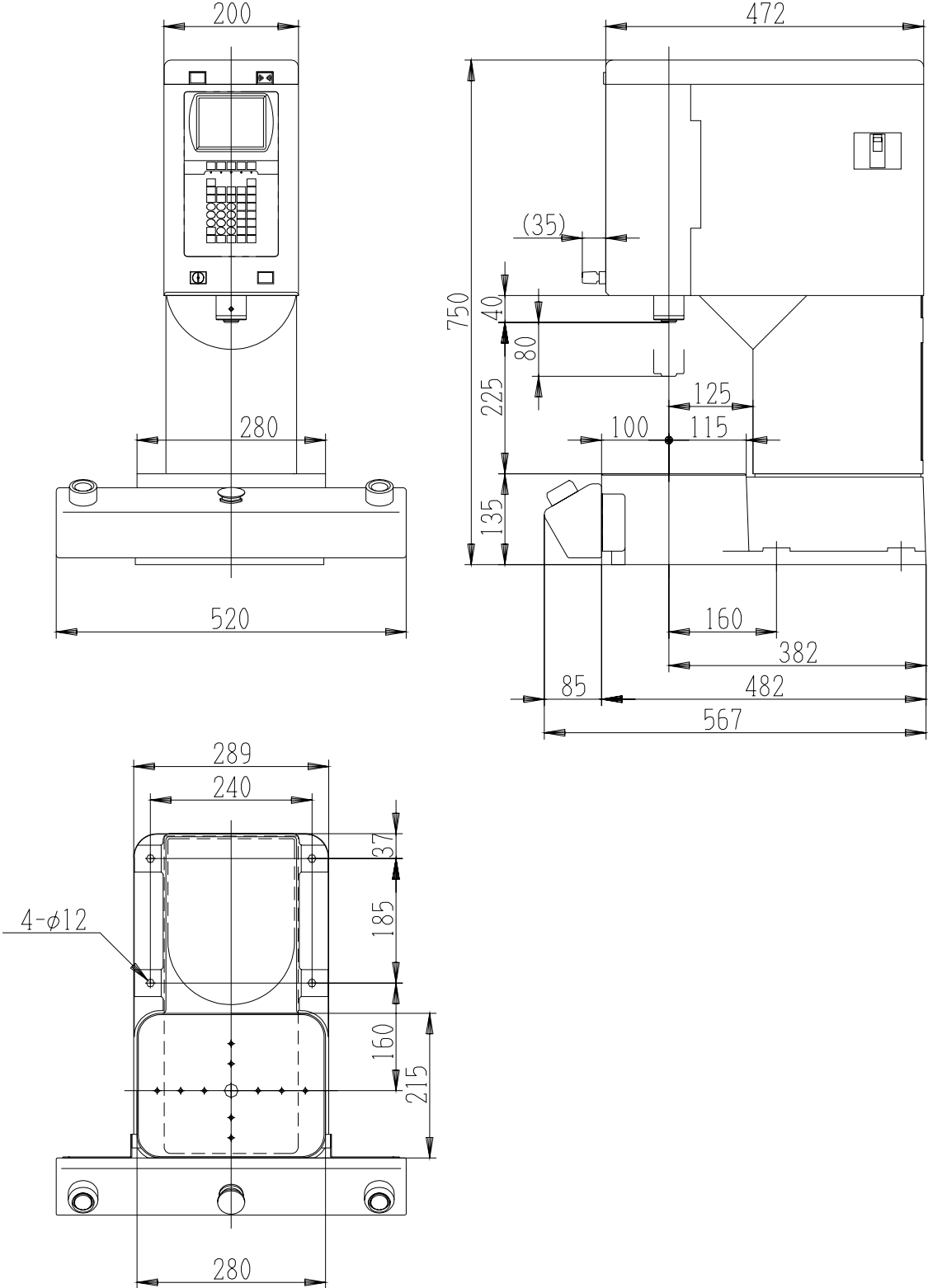

2-2 JP-504/JP-1004/JP-1504 Stand-Alone Type

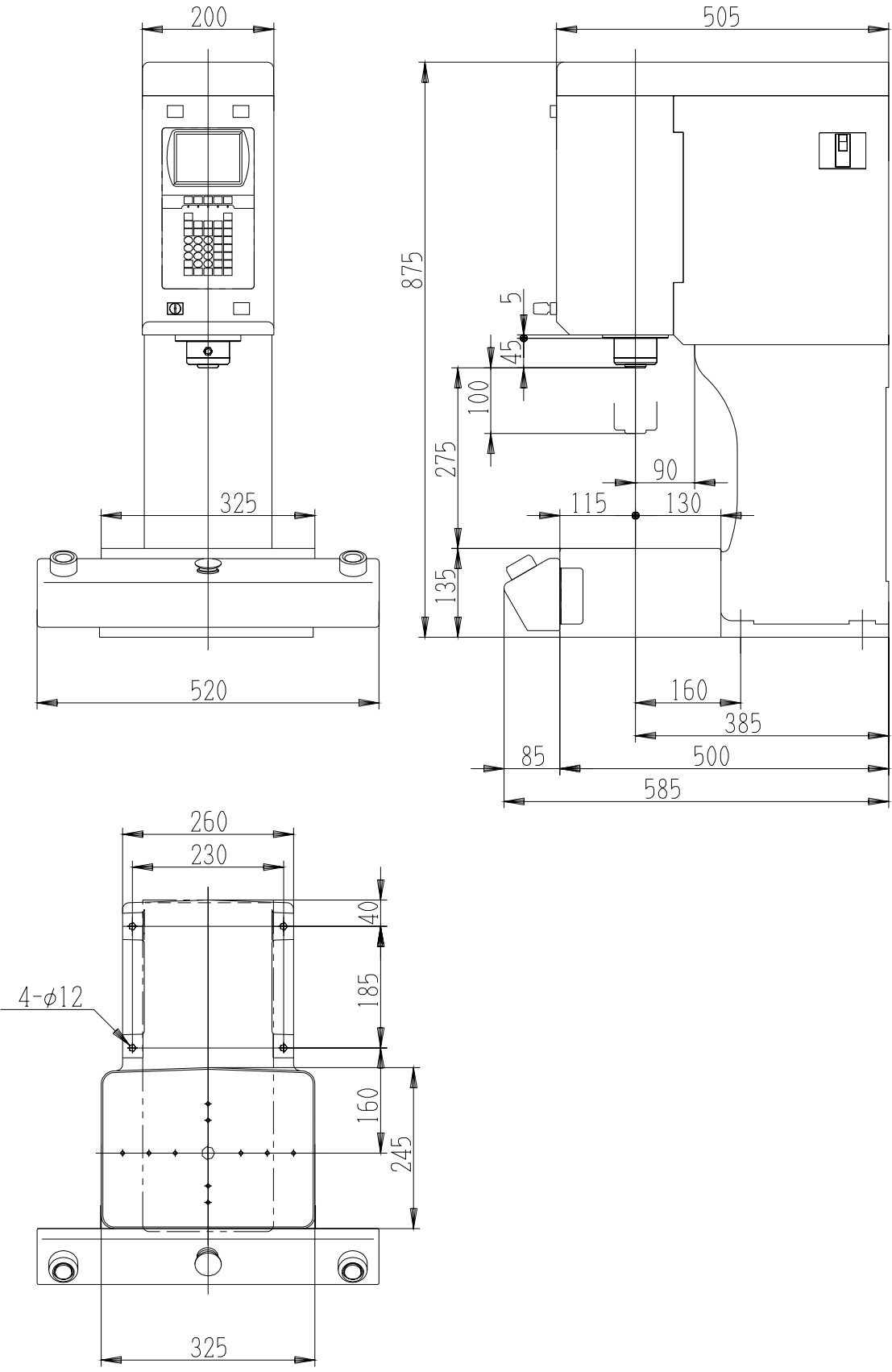

2-3 JP-3004/JP-5004 Stand-Alone Type

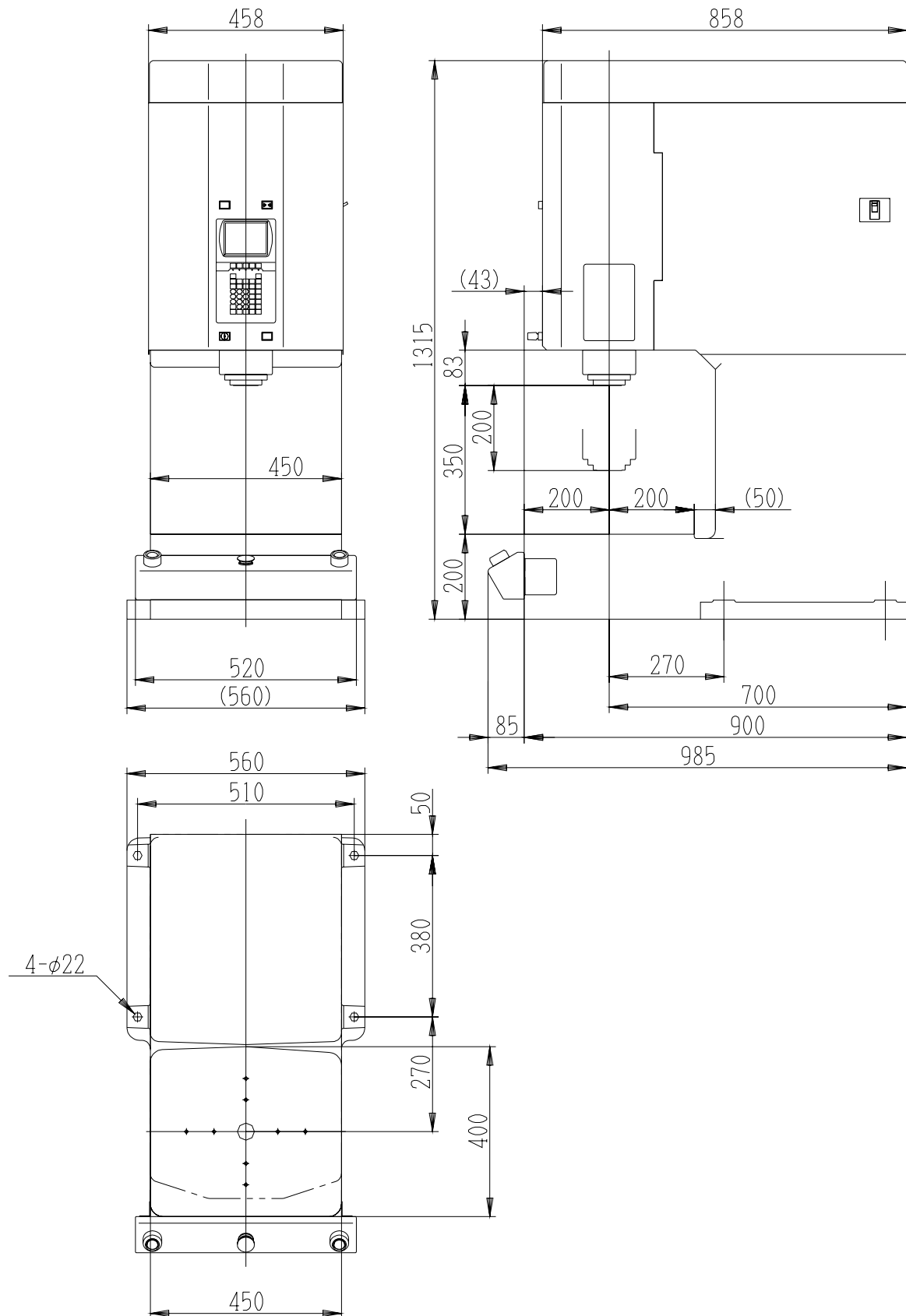

2-4 JPH-104/JPH-204 Head Type

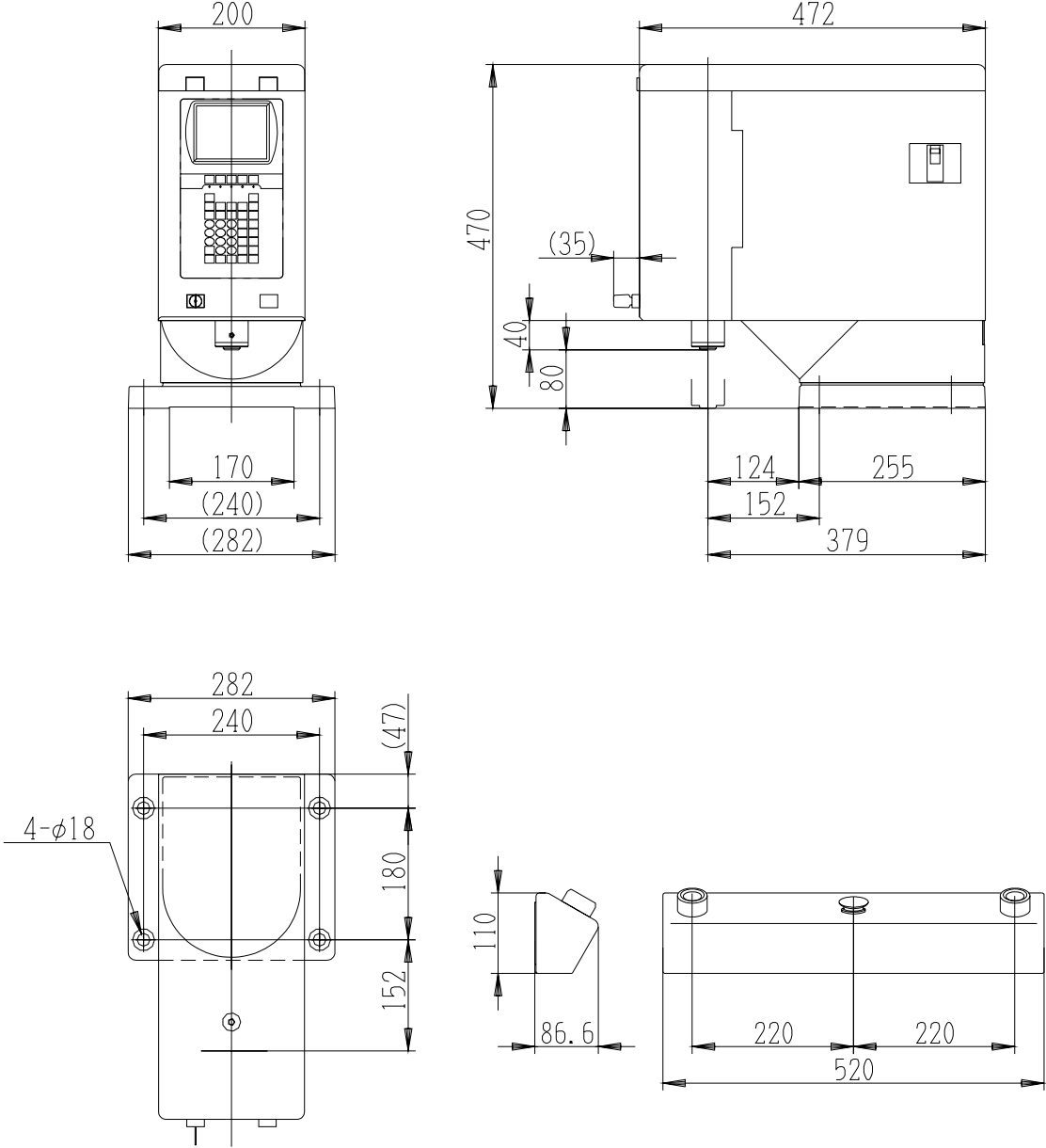

2-5 JPH-504/JPH-1004/JPH-1504 Head Type

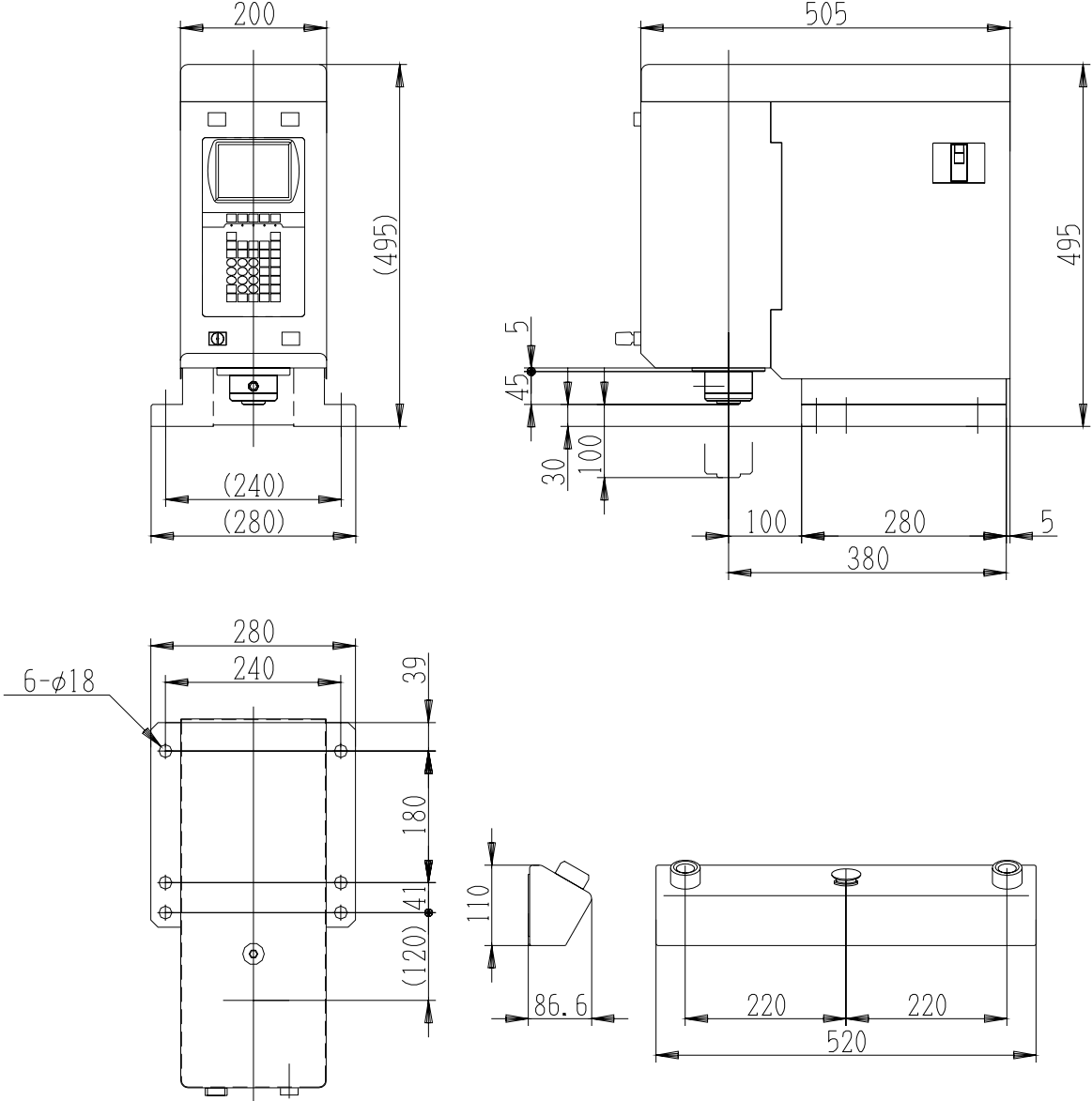

2-6 JPH-3004/JPH-5004 Head Type

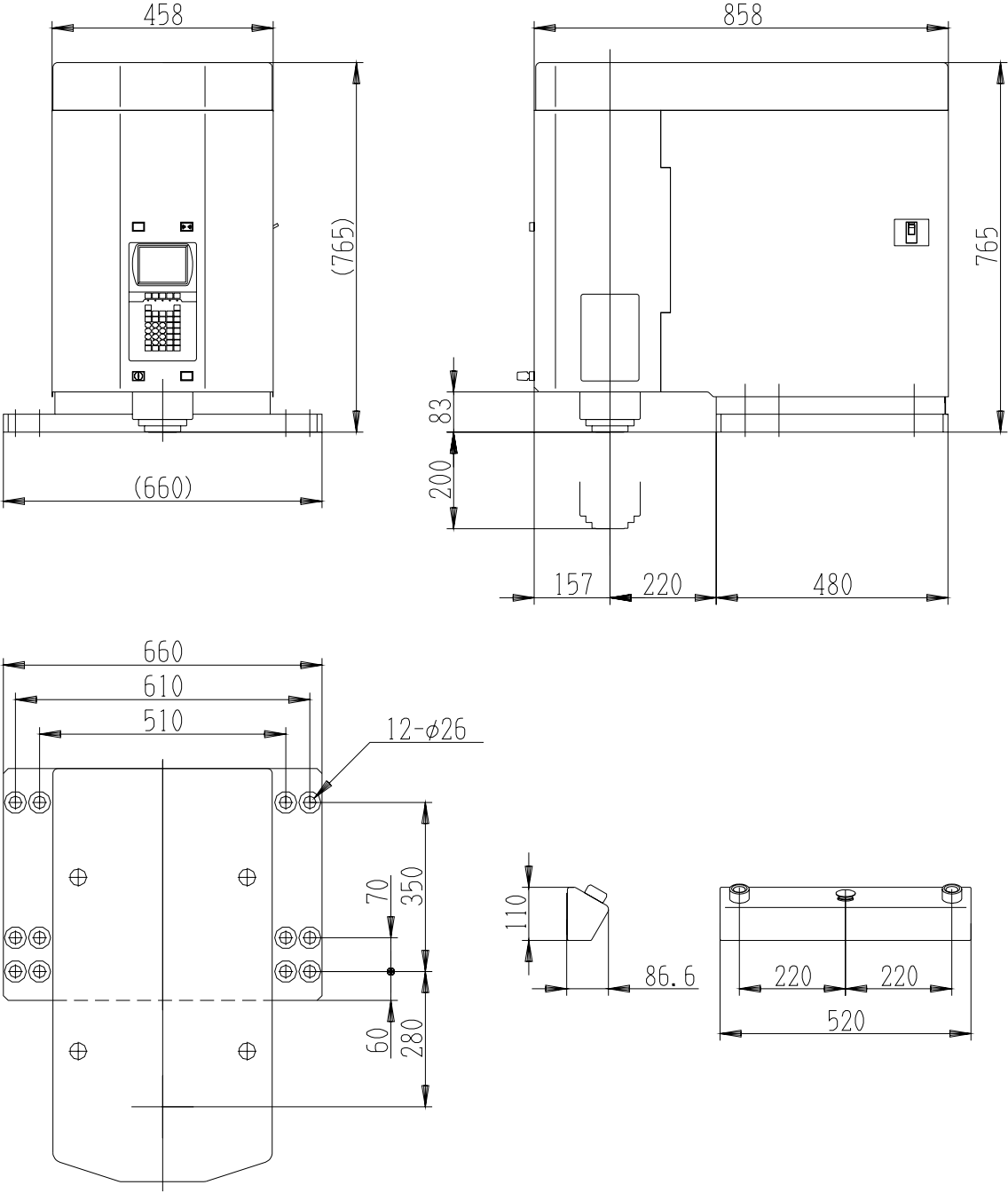

2-7 JPU-104/JPU-204 Unit Type

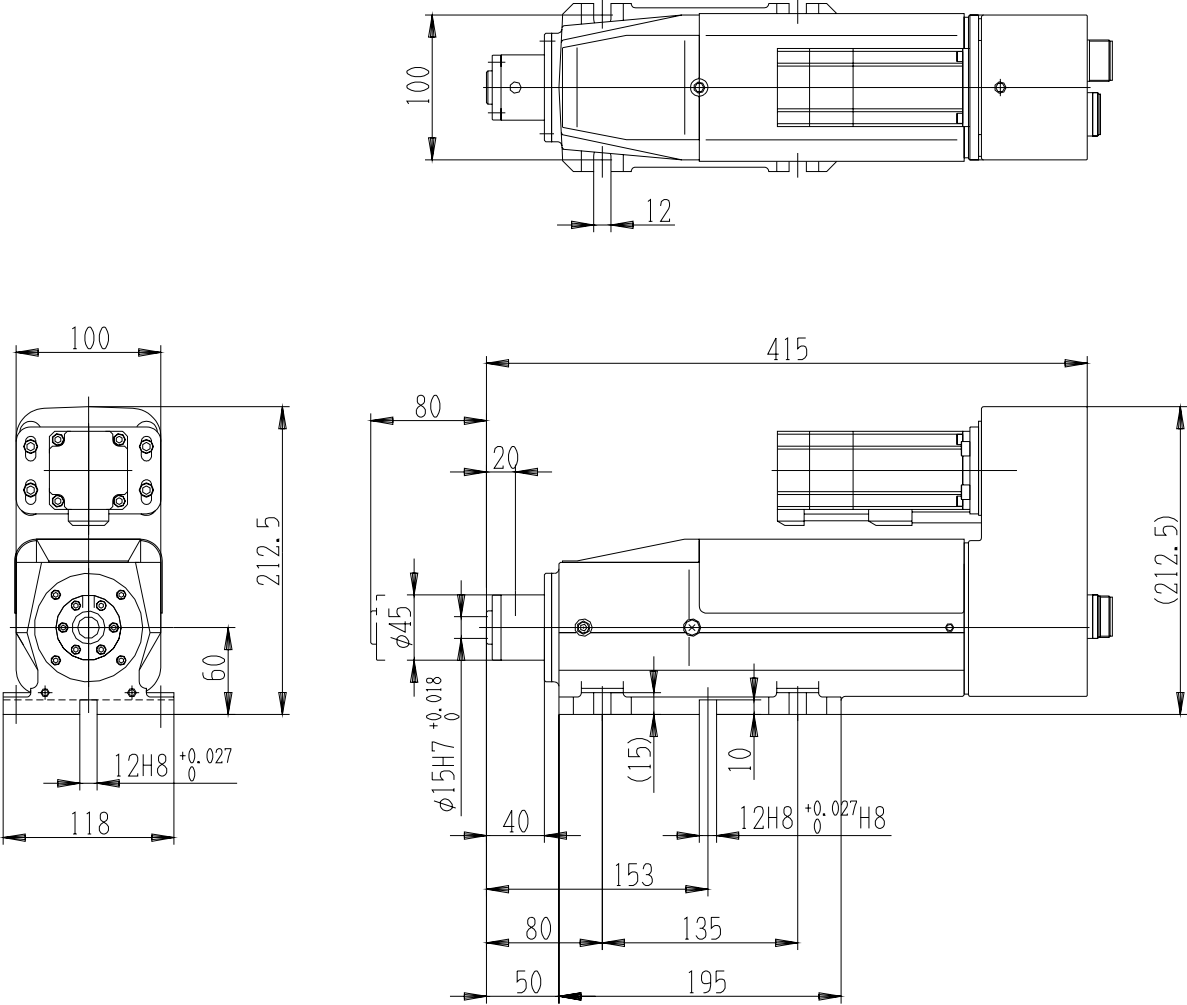

2-8 JPU-504/JPU-1004 Unit Type

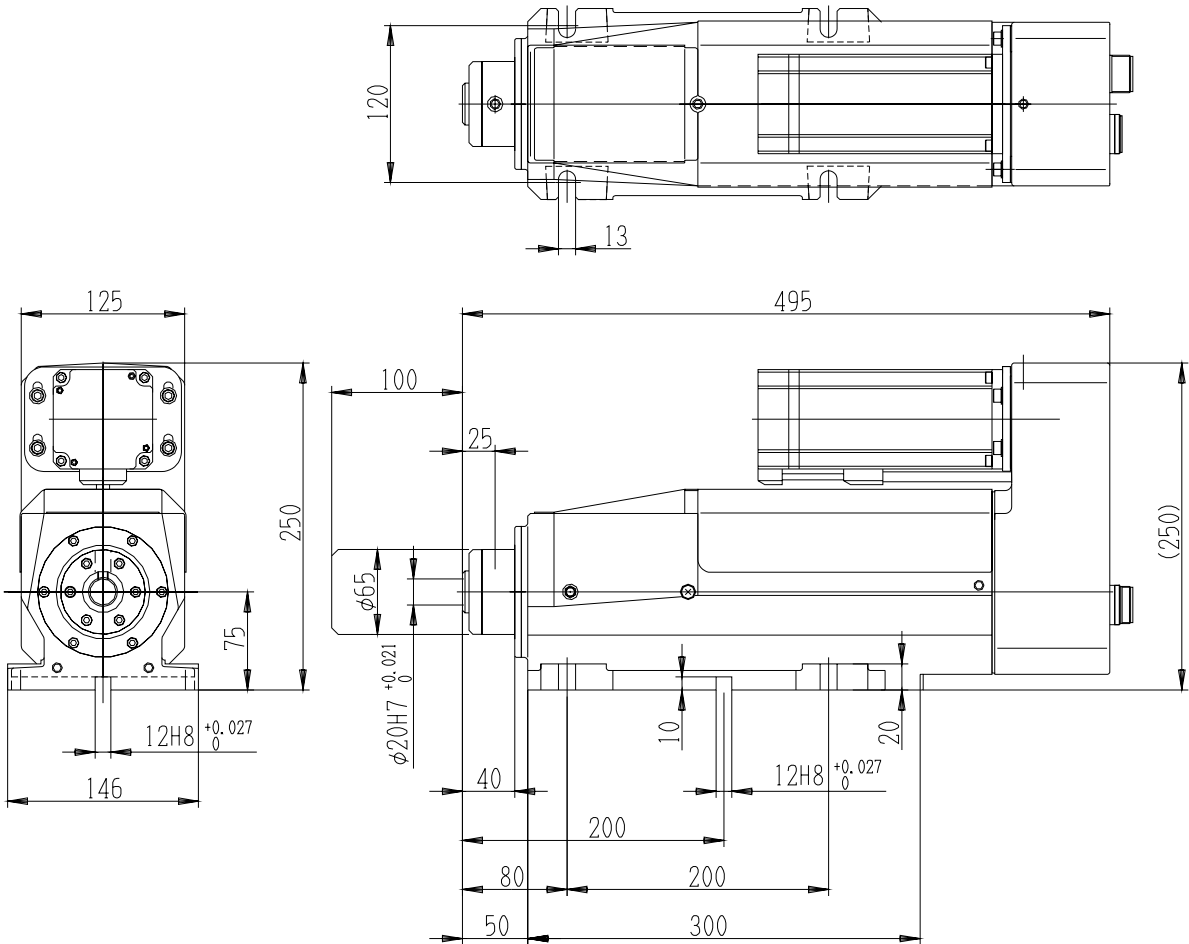

2-9 JPU-1504 Unit Type

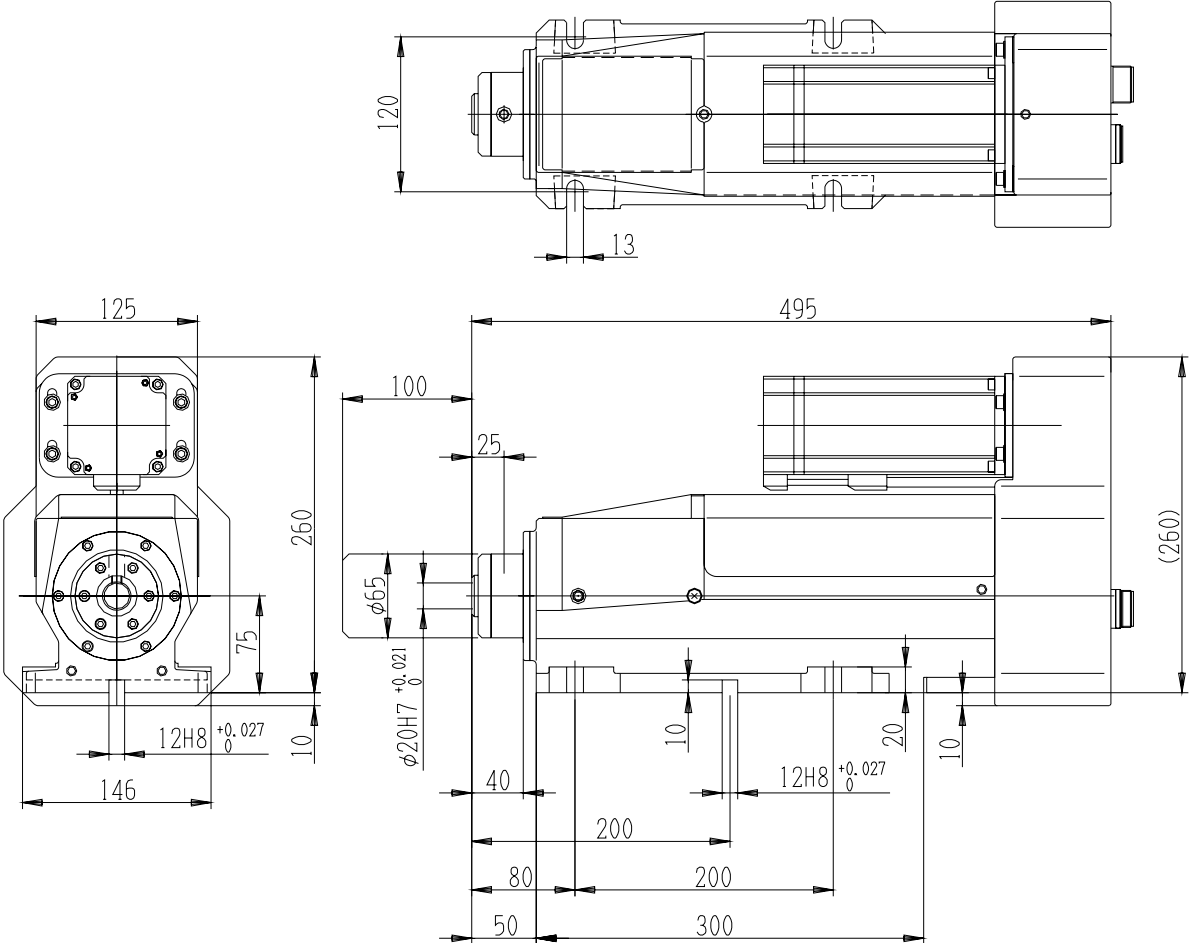

2-10 JPU-3004/JPU-5004 Unit Type

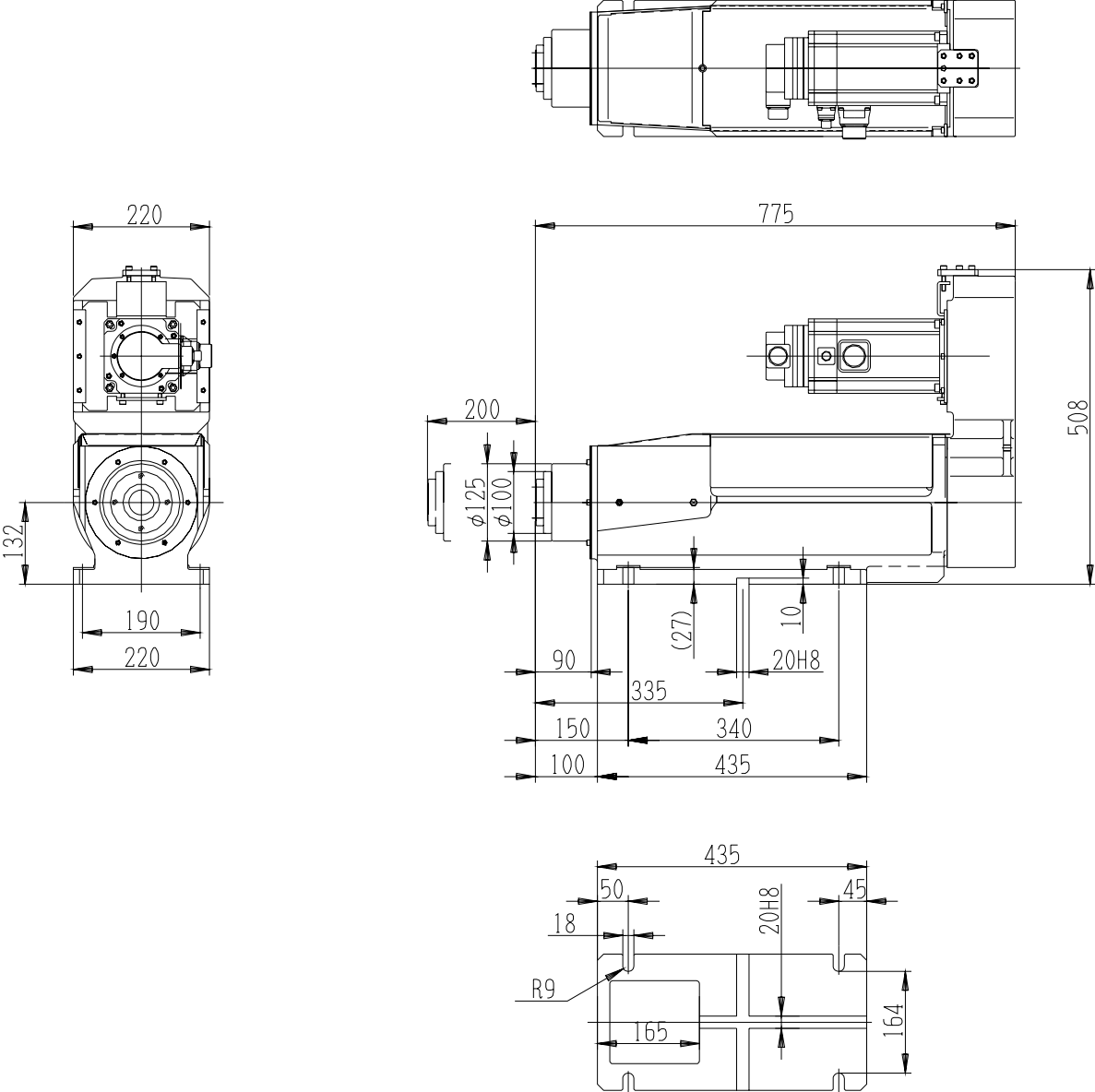

2-11 JPU-8004 Unit Type

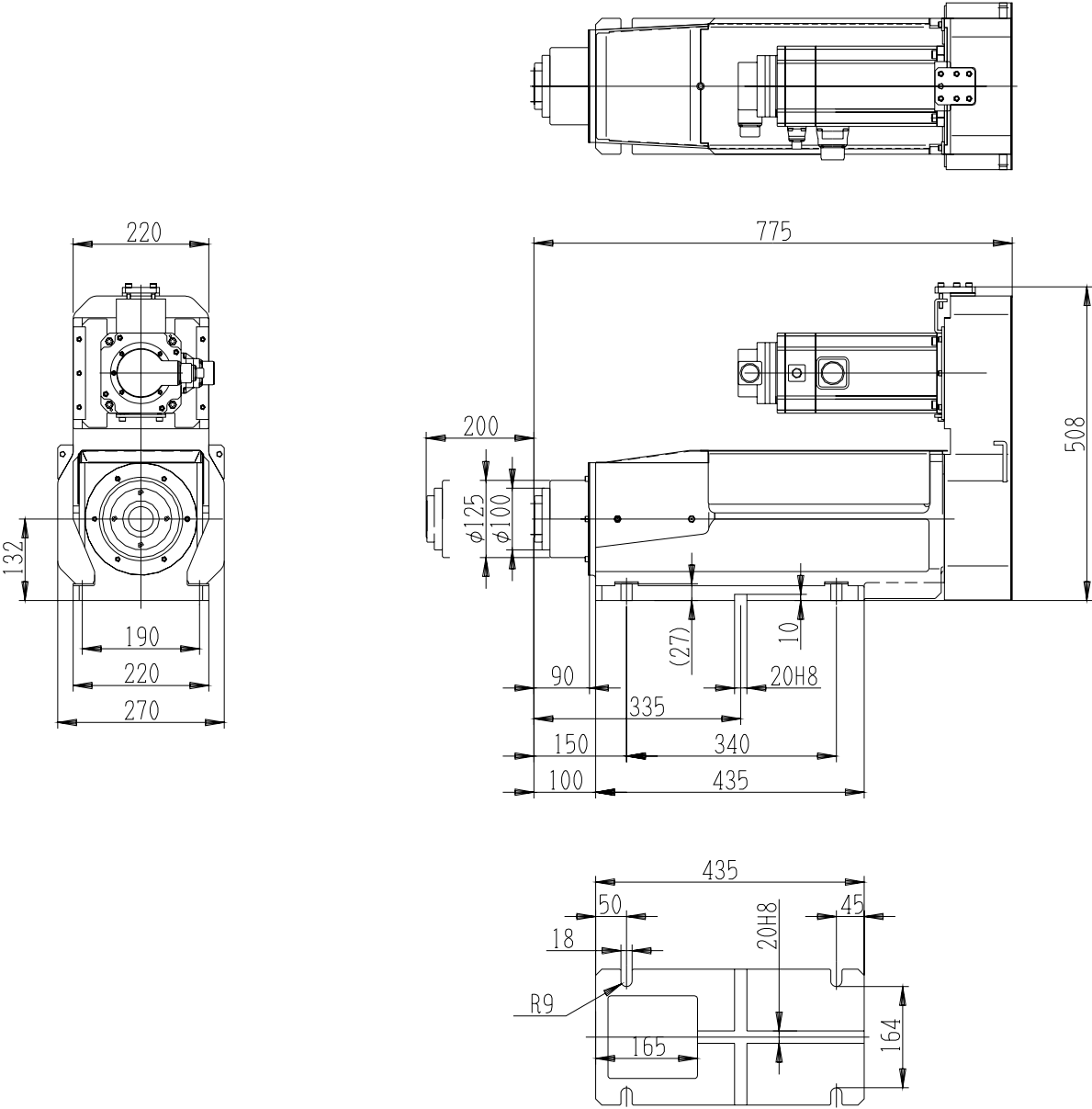

2-12 Control Box (JPB-104 to JPB-1504)

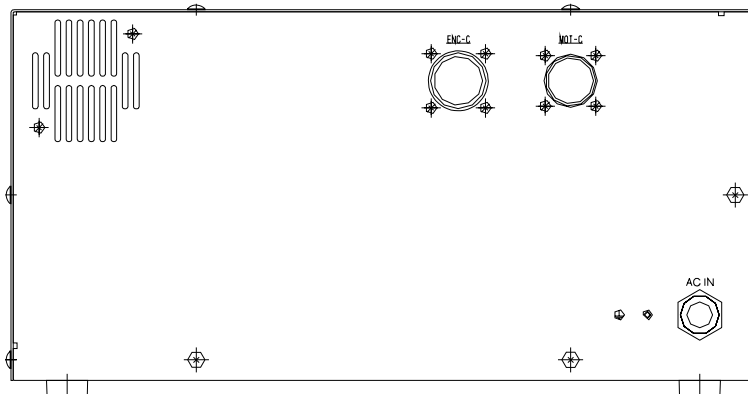
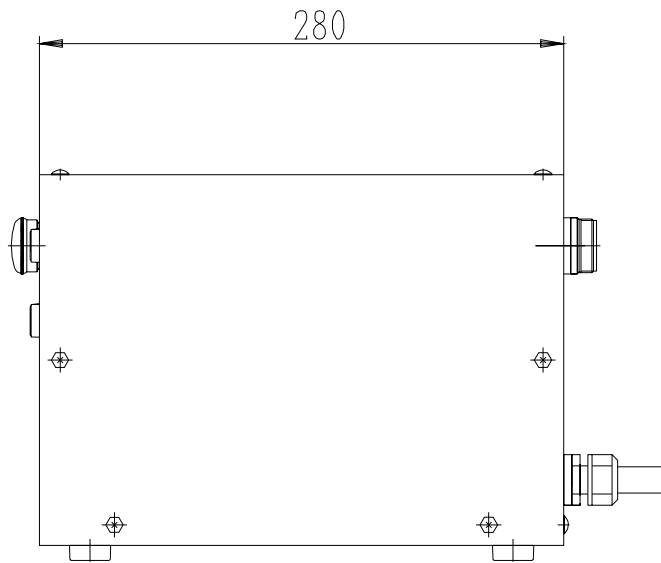
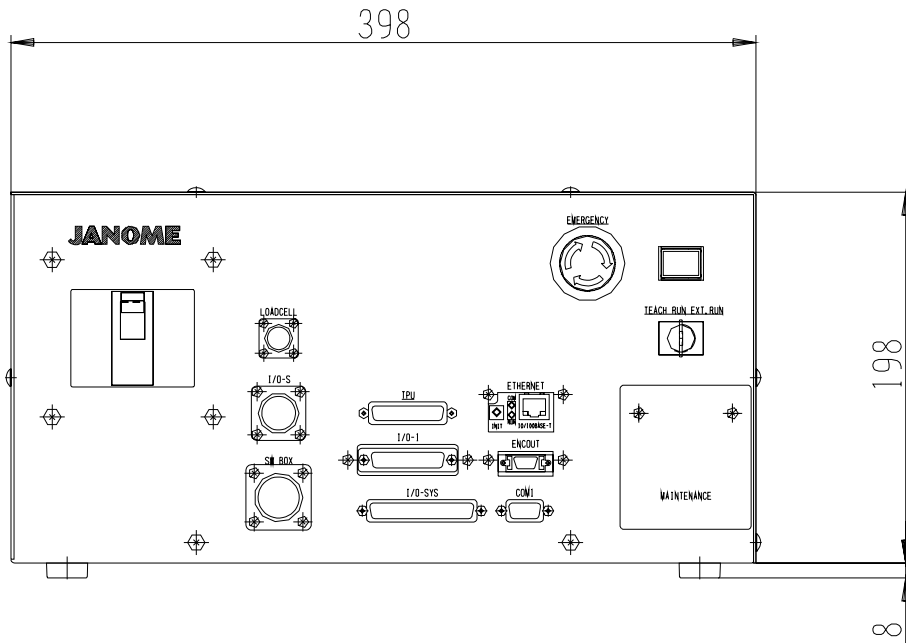

2-13 Control Box (JPB-3004 to JPB-8004)

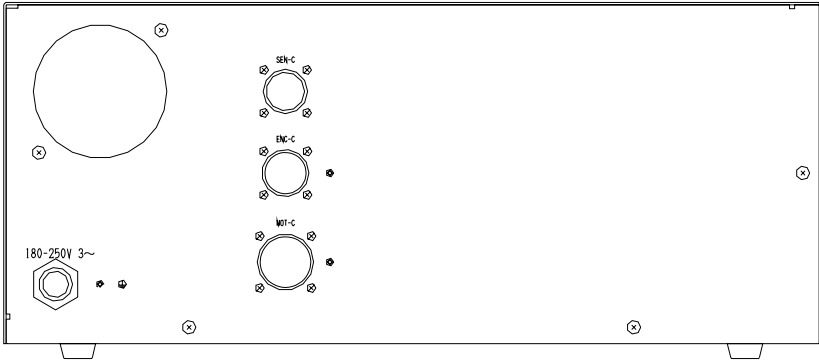
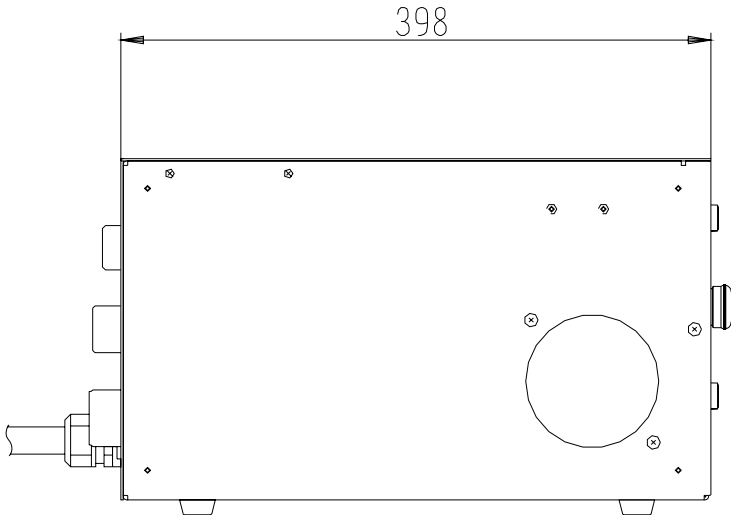
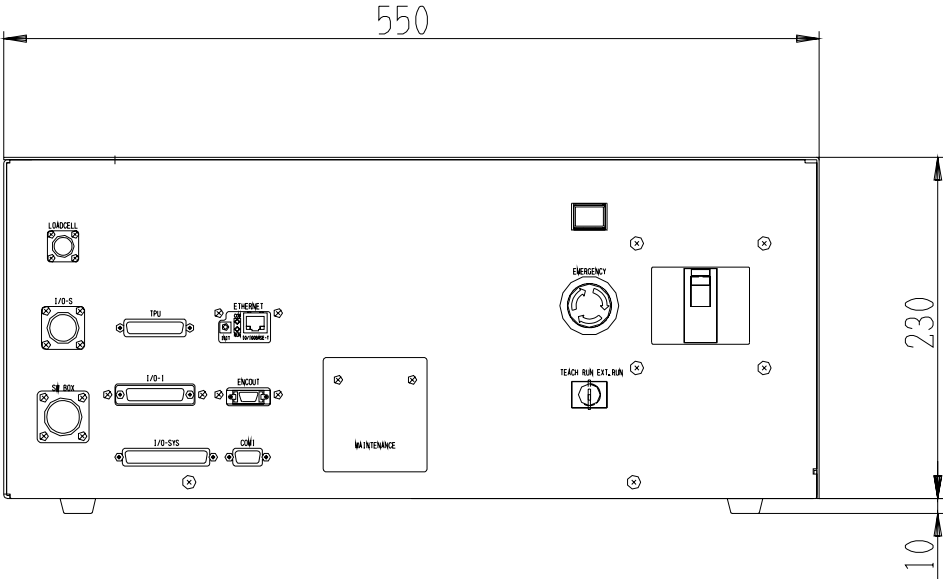

2-14 Teaching Pendant

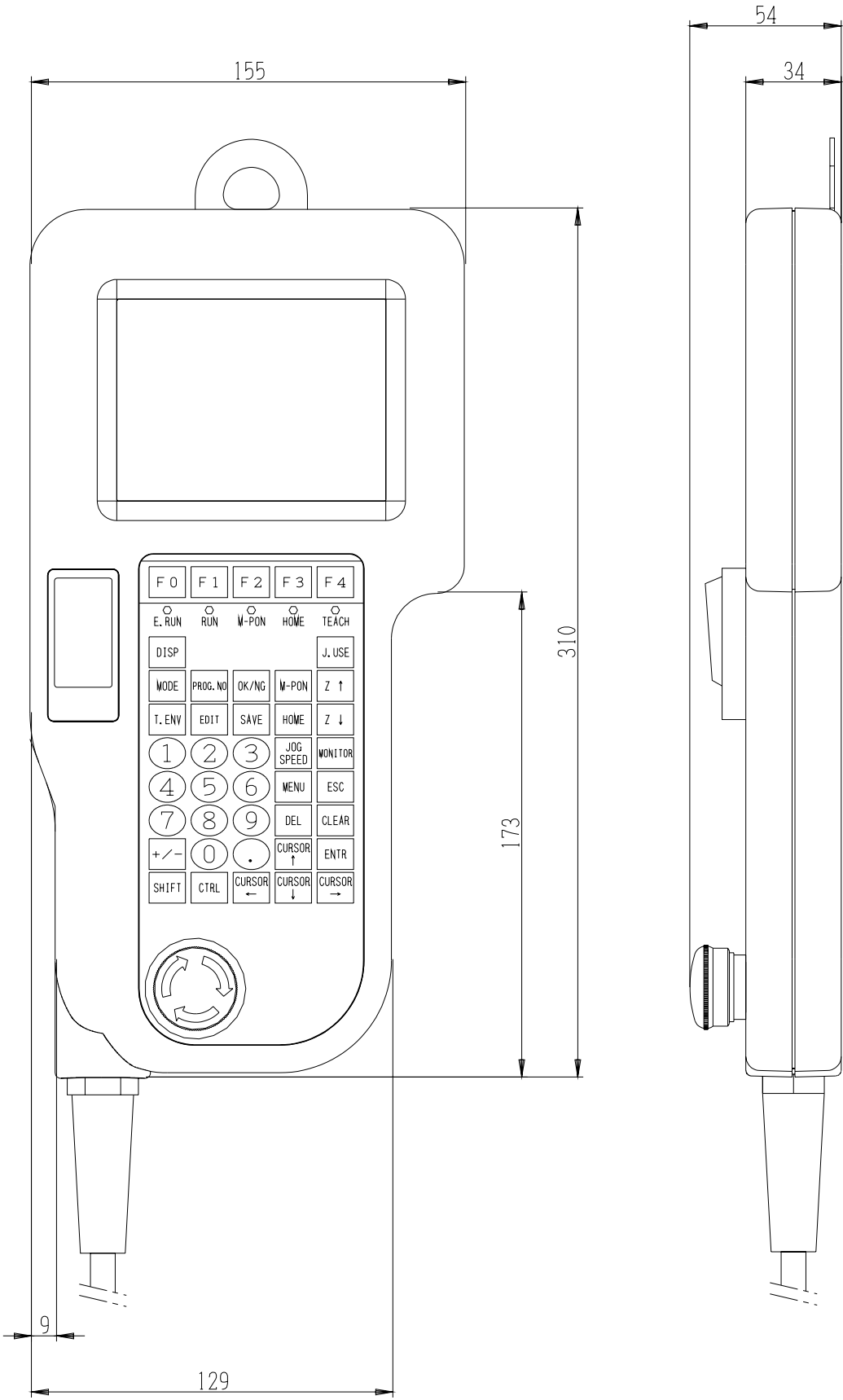

2-15 Monitor Box (Optional)

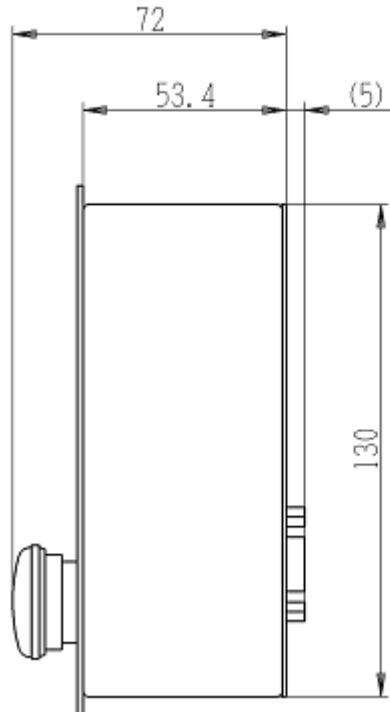
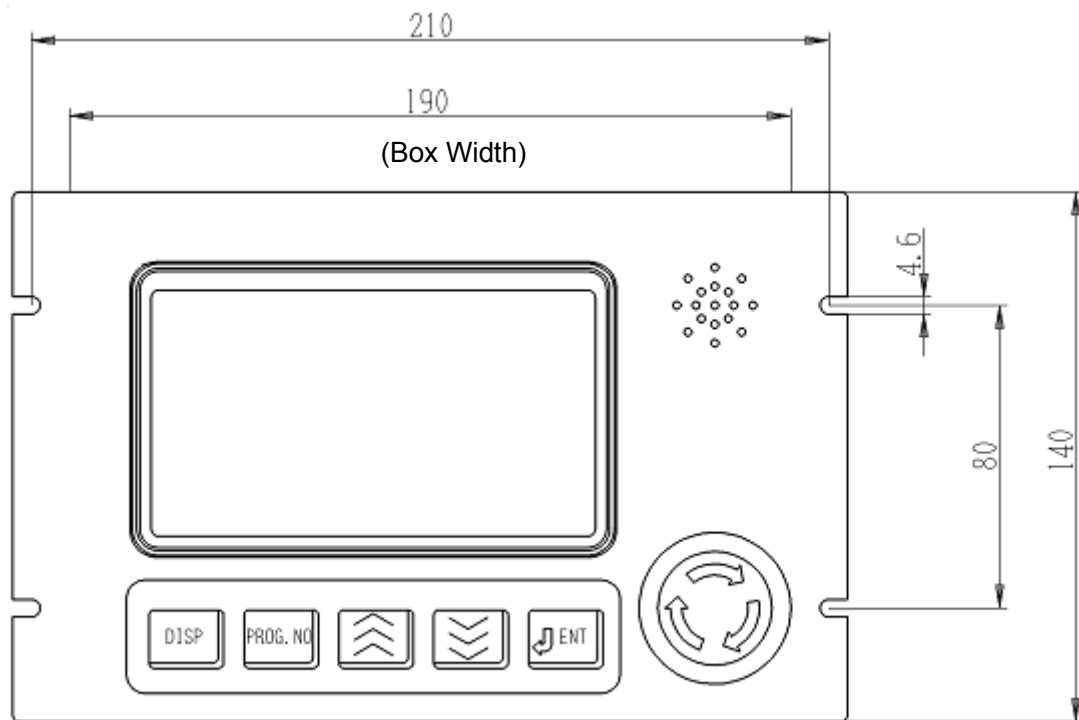

2-16 Switch Box (Optional)

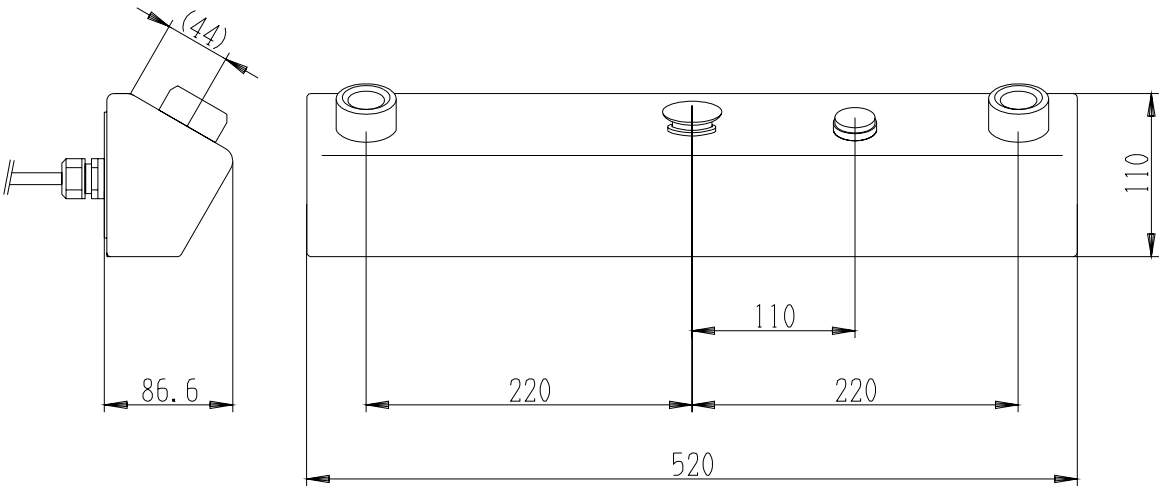

3. I/O-SYS

3-1 Connector

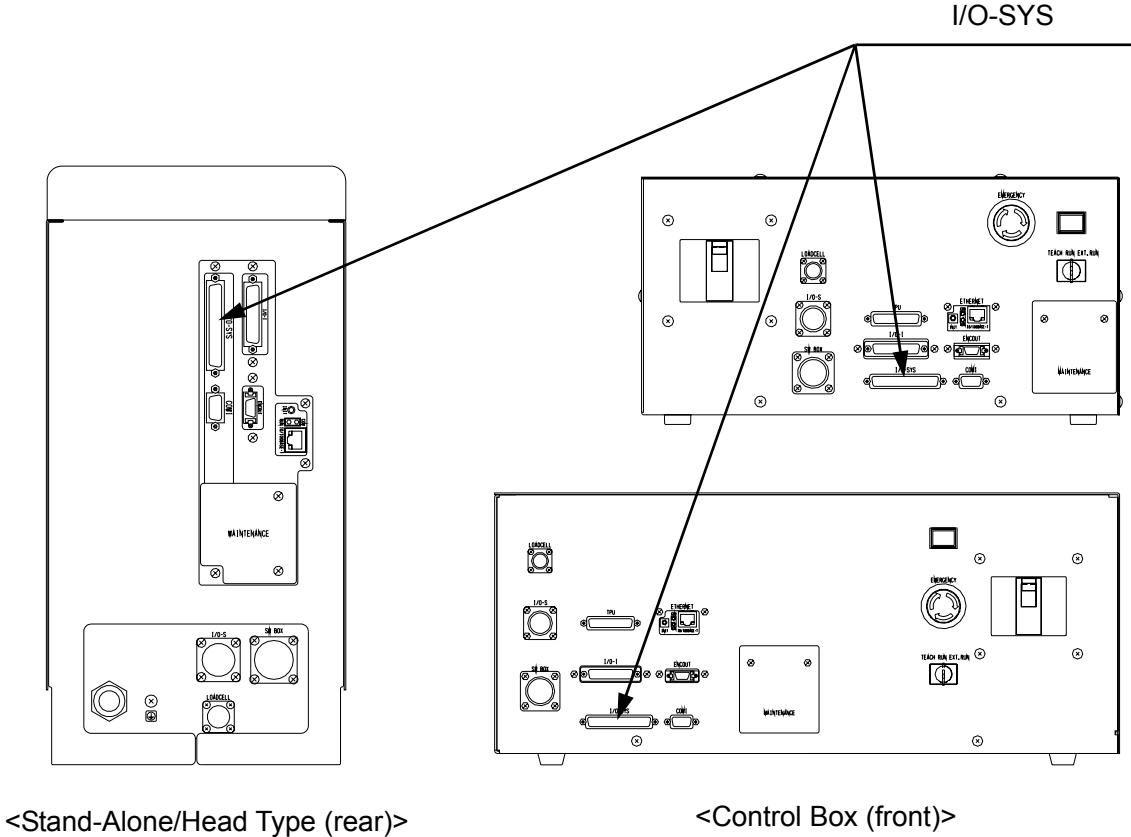

(Pin No.)

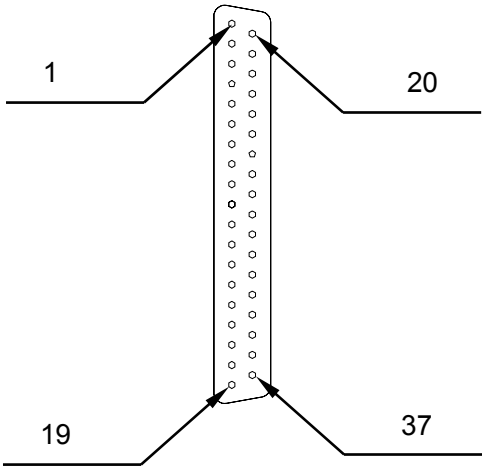

- * On the Electro press
- * On the control box

3-2 System Input/Output Functions of I/O-SYS Signals

The external I/O is furnished with 17 input pins and 16 output pins.

The IN17 (home position return) signal has the same function as the home position return switch.

External I/O signals are effective, except the start signal (IN1), both in the run (RUN) mode and in the external run (EXT. RUN) mode.

When in the teaching mode (except during the test run), all inputs and outputs, except the finish home (OUT2) signal, become ineffective and all outputs switch to OFF.

External I/O Inputs: 17 Pins, External I/O Outputs: 16 Pins

Input Pins

1. Start: Starts a program (Level, OFF End)
2. Error Stop: The ram stops immediately during operation. Operation will be restarted by a reset signal.
3. Descent Lock: the ram stops descending immediately and then returns to work home position when the signal turns OFF. It will not return an error.
4. Loading Program No.: Timing (edge) to load program number
5. PRG.No. B0 Program No. (b0) setting
6. PRG.No. B1 Program No. (b1) setting
7. PRG.No. B2 Program No. (b2) setting
8. PRG.No. B3 Program No. (b3) setting
9. PRG.No. B4 Program No. (b4) setting
10. PRG.No. B5 Program No. (b5) setting
11. PRG.No. B6 Program No. (b6) setting
12. Return to Work Home Position: The ram shifts to the work home position.
13. Reset: Stops alarm sound in case of error and turns off error output.
14. Stop Pressing: The ram stops when this signal turns ON during operation and restarts pressing when this signal turns OFF.
15. Stop in Middle: The ram stops when this signal comes ON during pressing and then enters holding time. The operation terminates when this signal comes ON within holding time and then the ram returns to the work home position.
16. Sampling Signal: Inputs timing for position and load sampling
17. Home Position Return: Turns on the power to the motor and performs mechanical initialization.

100 different programs can be selected.



Warning

Be sure to use protective measures such as an area sensor or enclosure if you run the Electro Press via the external I/O.

Each stop signal functions as follows:

- IN2 (Error Stop)
 - Standby: Unable to start, no system error results.
 - Approach: The ram stops and waits for a reset signal. System error results.
 - Pressing: The ram stops and waits for a reset signal. System error results.
 - Holding time: The ram stops and waits for a reset signal. System error results.
 - Ascending: The ram stops and waits for a reset signal. System error results.

- IN3 (Descent Lock)
 - Standby: Unable to start, no system error results.
 - Approach: The ram stops and then ascends to work home when this signal turns OFF.
No error results.
 - Pressing: The ram stops and then ascends to work home when this signal turns OFF.
No error results.
 - Holding time: Invalid
 - Ascending: Invalid

- IN14 (Stop Pressing)
 - Standby: Invalid
 - Approach: Invalid
 - Pressing: The ram stops and restarts pressing when this signal turns OFF.
 - Holding time: Invalid
 - Ascending: Invalid

- IN15 (Stop in Middle)
 - Standby: Invalid
 - Approach: Invalid
 - Pressing: The ram stops and enters the holding time.
 - Holding time: The ram stops and then ascends.
 - Ascending: Invalid

Output Pins

1. Ready for start: the external I/O is Ready for start.
2. Finish Home: The home position return is finished.
3. Acknowledge Program No.: OK/NG sensor for acknowledged program number change
4. Program No. Error: Program (teaching data) number setting error signal at start when the total selected program number is larger than 100 or the program with no teaching data is selected
5. Sensor Fault: Fault (NG) in sensor
6. Sensor Fault (U/L): Upper limit (ON)/lower limit (OFF) of sensor fault
7. Sensor Fault JB0: Bit 0 at sensor fault No. J ("J" indicates a number)
8. Sensor Fault JB1: Bit 1 at sensor fault No. J ("J" indicates a number)
9. Error: An error has occurred.
10. Power OFF: Request signal to restore the power used in case the servo motor is tripped, etc.
11. Request Home: Request signal to return to the home position: without returning to the work home, operation will not to be restored even after the power turns on.
12. Play Back: Operating in progress
13. Pressing: the ram is applying pressure to the workpiece.
14. Ascending/Standby: the ram is ascending/on standby for start after pressing/holding time.
15. Recognizing Emergency Stop: emergency stop switch was pressed.
16. Sampling Signal ACK: performs data samplings for position and load by signals.

Output9 "Error" contains the following errors.

- Pressure Error: The ram ascends to the work home position and enters standby mode.
- Ram Travel Error: The ram ascends to the work home position and enters standby mode.
- Stop in Middle Error (pause start signal): The ram ascends to the work home position and enters standby mode.
- Stop in Middle Error (error stop by IN2): The ram stops: return the ram to the home position.
- Stop in Middle Error (emergency stop): The ram stops: return the ram to the home position.
- Servomotor Trip Error: The ram stops: turn power off and on again.
- Memory Card Not Inserted: Turn power off and on again.
- Hardware Error: Turn power off and on again. (Trap error, RAM check error, SUM error, device error such as EEPRO, sensor switch error, etc.)
- Motor Initialize Error: turn power off and on again.

Note:

When a Program No. error or Sensor Fault error occurs, OUT4 and OUT5 come ON respectively, but an error signal (OUT9) does not come ON.

Sensor Fault Code

OUT8	OUT7	OUT6	
OFF	OFF	OFF	: J1 sensor lower limit fault
OFF	OFF	ON	: J1 sensor upper limit fault
OFF	ON	OFF	: J2 sensor lower limit fault
OFF	ON	ON	: J2 sensor upper limit fault
ON	OFF	OFF	: J3 sensor lower limit fault
ON	OFF	ON	: J3 sensor upper limit fault
ON	ON	OFF	: J4 and succeeding sensor lower limit fault
ON	ON	ON	: J4 and succeeding sensor upper limit fault

3-3 I/O-SYS Circuit Diagram

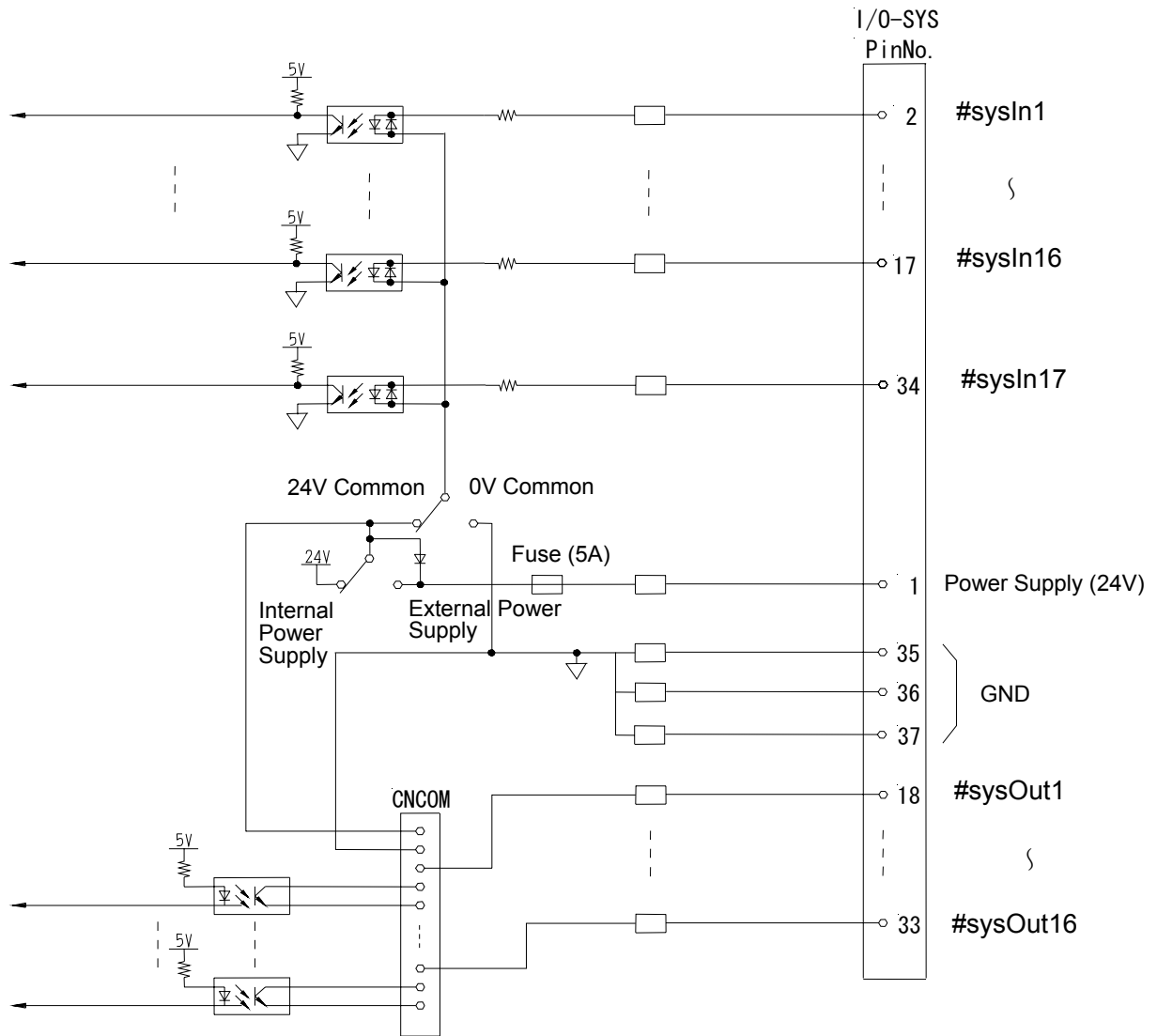

3-4 I/O-SYS Input Signal (Sink Input)

Input signals are active when the photo coupler is ON.

Internal Power Supply

When an internal power supply is used, the input pin and the COM- pin below should be shorted as shown.

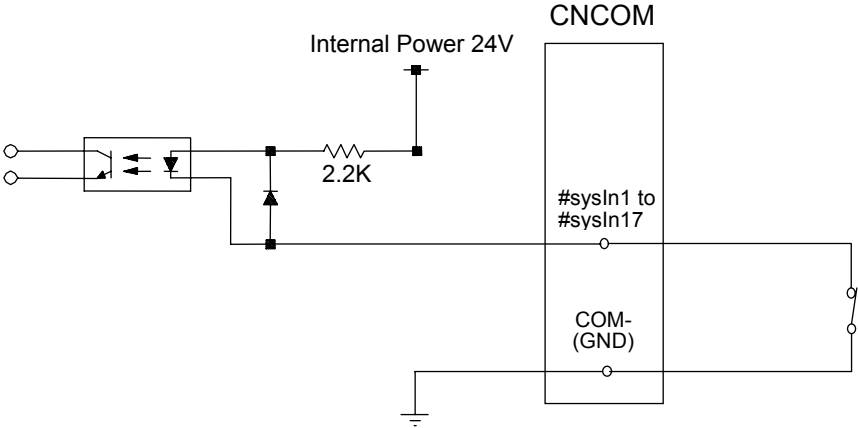

External power Supply

When an external power supply is used, input pins and the external power ground should be ON as shown below.

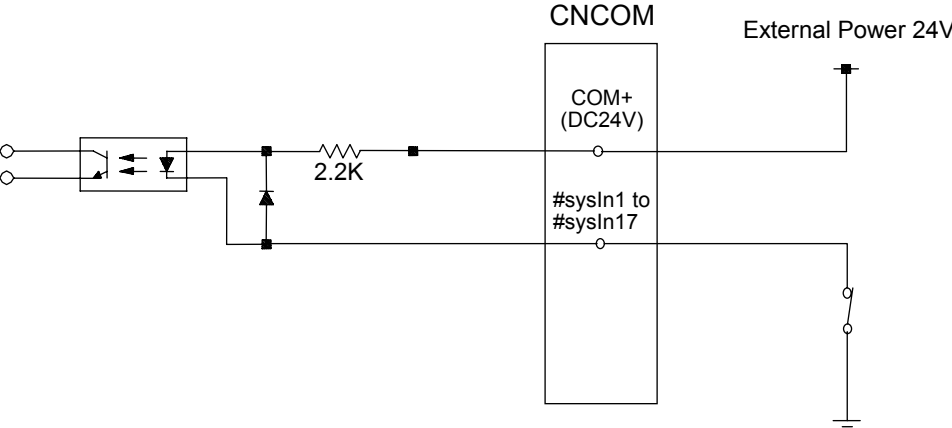

3-5 I/O-SYS Output Signal (Sink Output)

Internal Power Supply

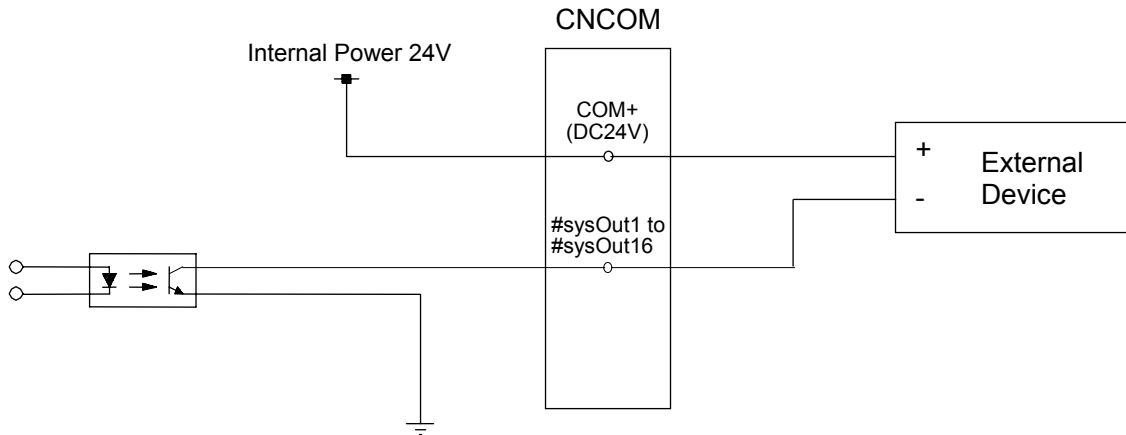

External Power Supply

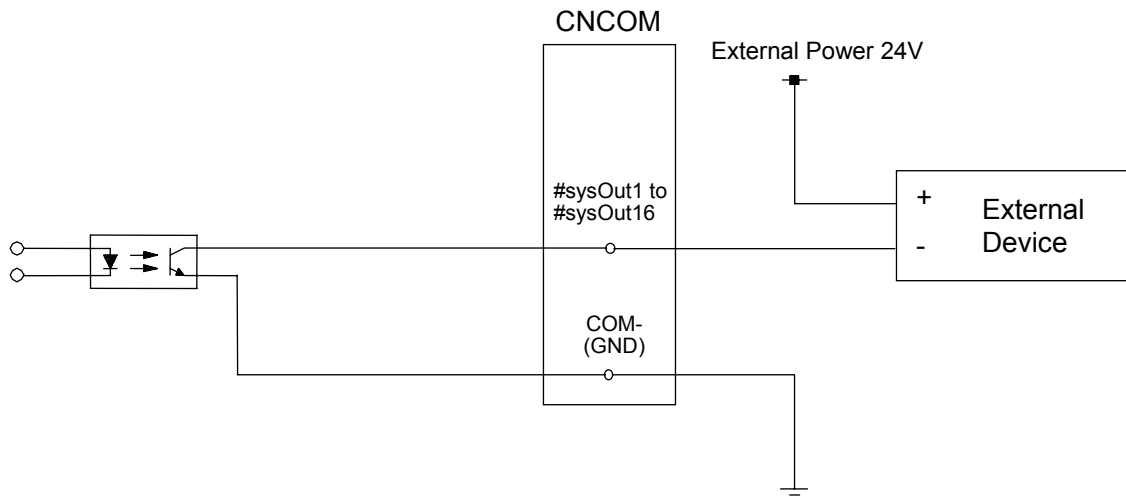

3-6 I/O-SYS Output Capacity (Sink Output)

For both the internal power supply and external power supply, use rated voltage not more than the following.

- 100 mA for 1 pin (DC24V)

For the internal power supply, use rated voltage not more than the following.

- DC24V, 2A (Total of the I/O-SYS and I/O-1)

3-7 I/O-SYS Input Signal (Source Input)

Input signals are active when the photo coupler is ON.

Internal Power Supply

When an internal power supply is used, the input pin and the COM+ pin below should be ON as shown.

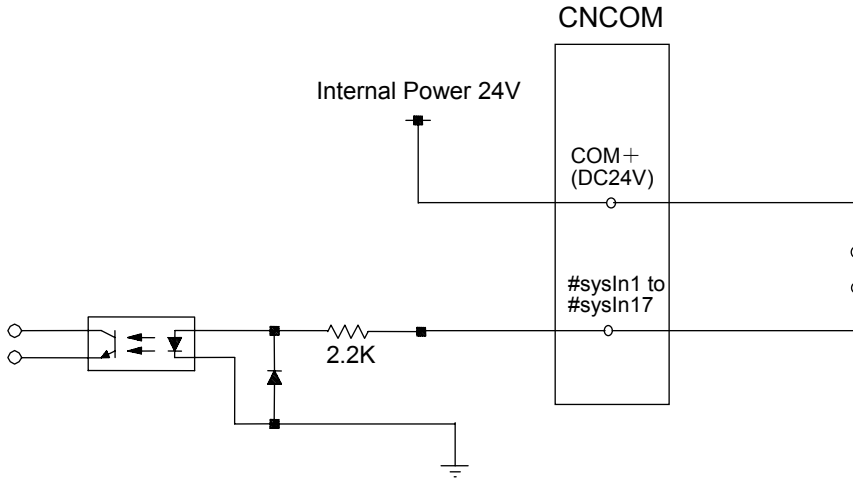

External Power Supply

When an external power supply is used, the input pin and external power below should be ON as shown.

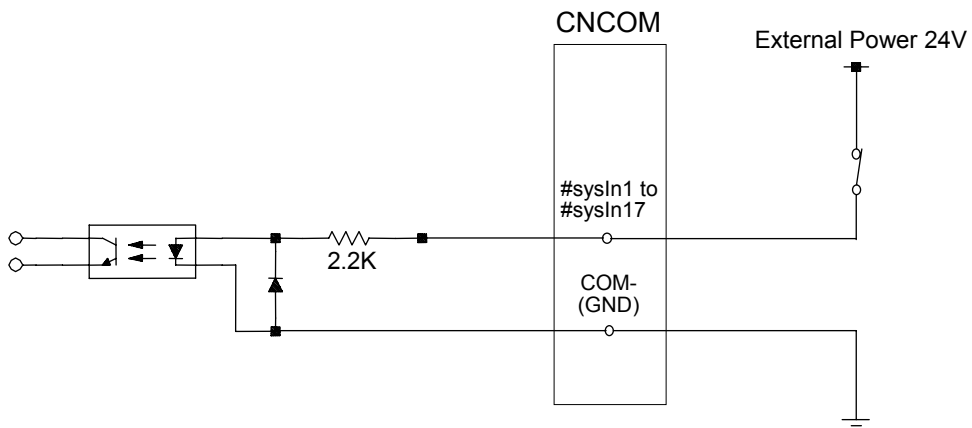

3-8 I/O-SYS Output Signal (Source Output)

Internal Power Supply

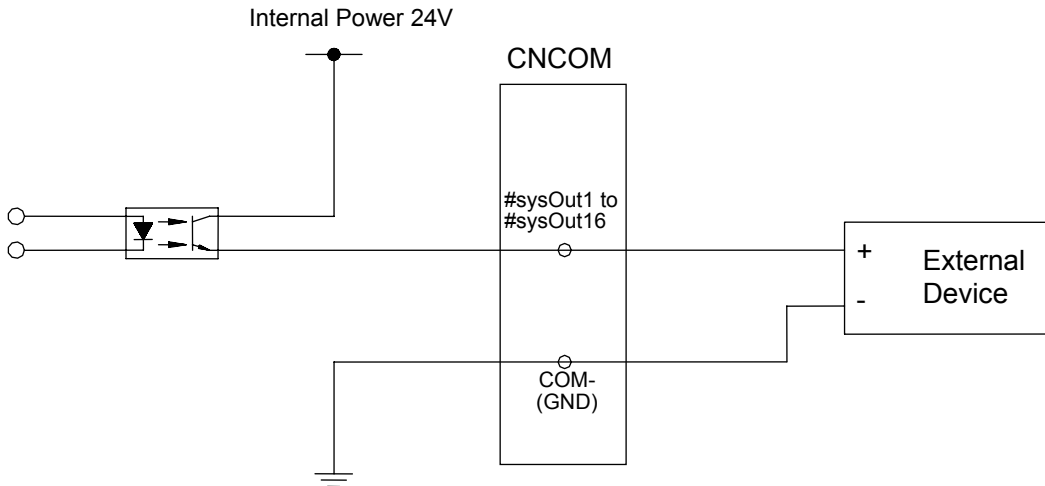

External Power Supply

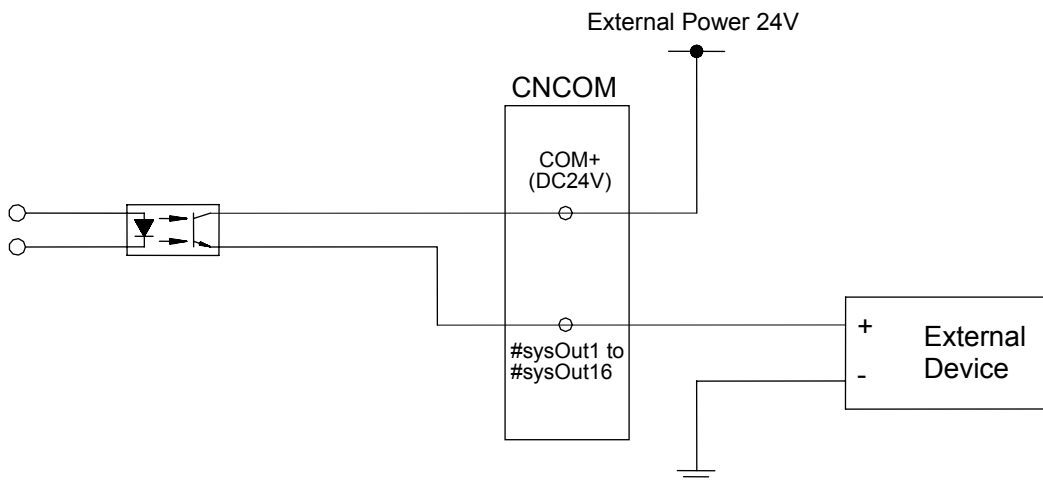

3-9 I/O-SYS Output Capacity (Source Output)

For both the internal power supply and external power supply, use rated voltage not more than the following.

- 100 mA for 1 pin (DC24V)

For the internal power supply, use rated voltage not more than the following.

- DC24V, 2A (Total of the I/O-SYS and I/O-1)

3-10 Switching I/O-SYS Power Supply

Turn OFF the Electro Press and remove the cover on the rear body (Stand-alone/Head type) or the cover on the control box (front) (Unit type) to adjust the following switches.

Switch	Display	IN	EXT
I/O-SYS Power Selection Switch		Internal Power Supply	External Power Supply

Body (Rear),
Stand-Alone/Head Type

Control Box (Front), Unit Type

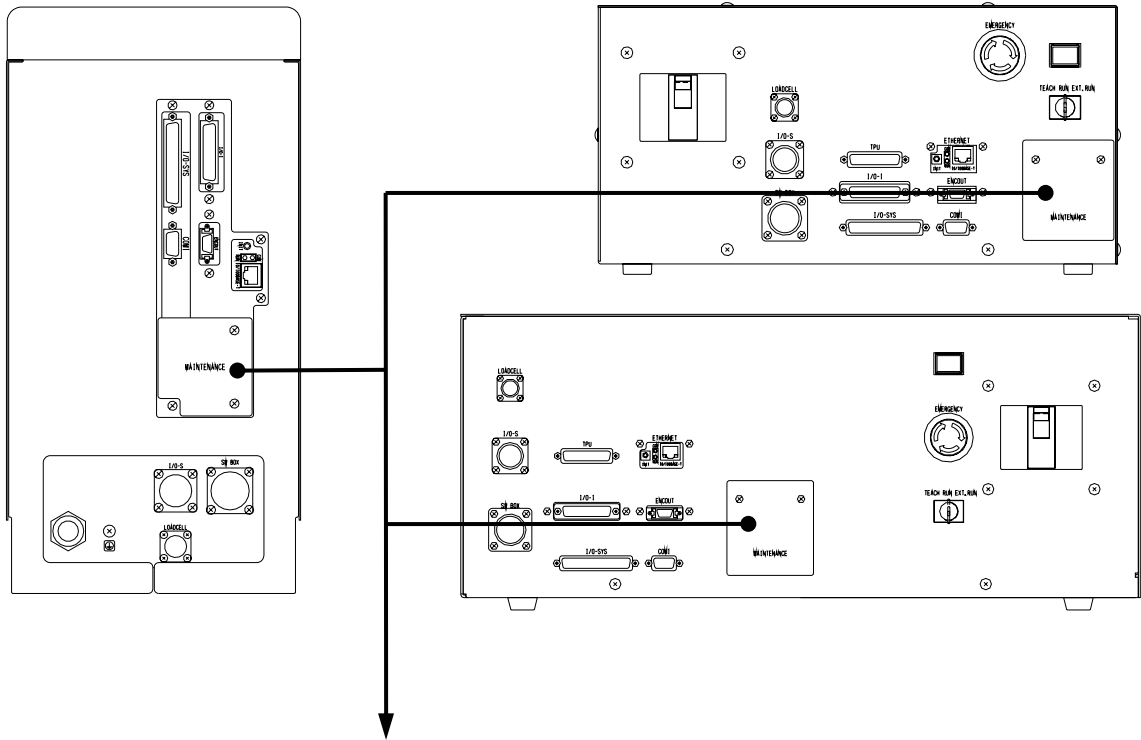

Inside the Cover

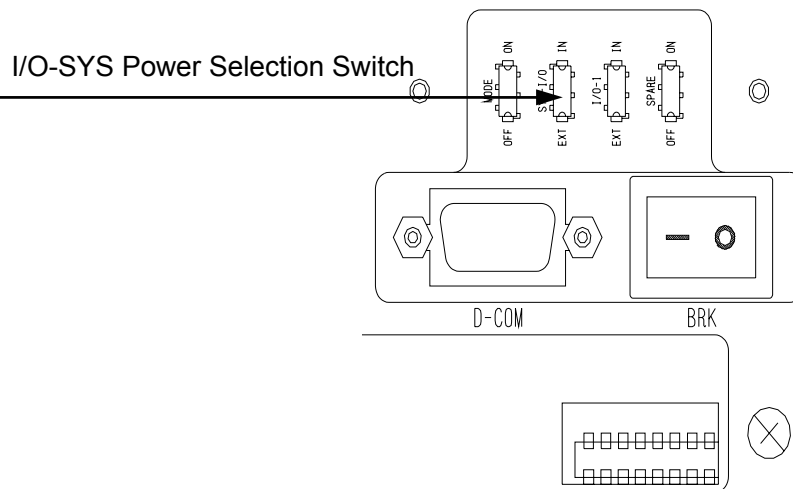

3-11 I/O-SYS Timing Chart

- The operation process from the power being turned on and the program read to start operation (should be set to external run mode)

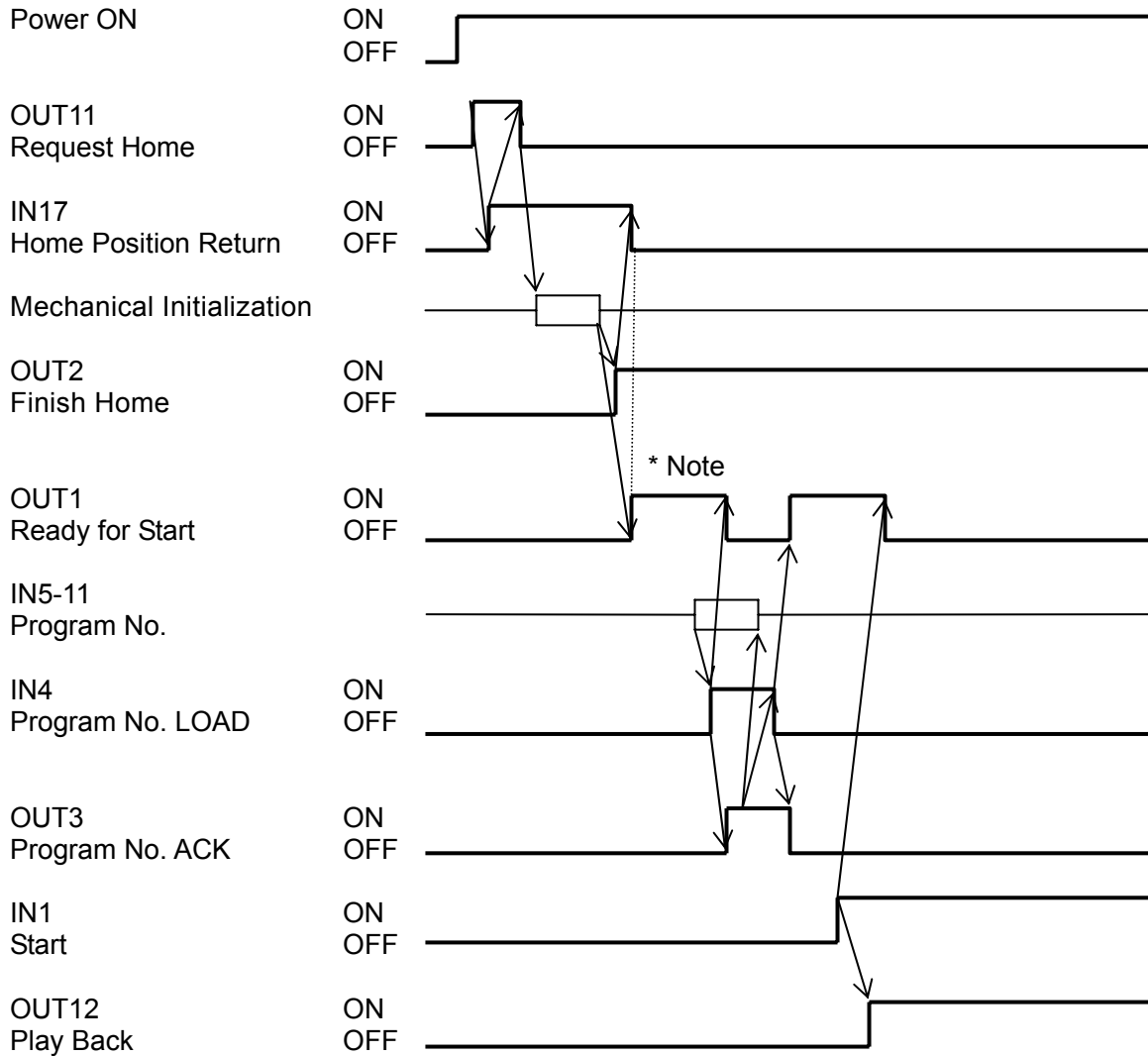

*** Note:**

Normally, the Ready for Start signal is sent after the ram has returned to the work home position. However, in case the ram returns to the home position and initializes, the Ready for Start signal will be sent when the ram is at the home position, not at the work home position. Although the ram is at the home position, the Electro Press performs a one shot operation after receiving the start signal.

● **The operation from the normal start to the end**

The ram starts descending by the IN1 (start) ON signal. The IN1 ON signal must be sustained until the ram starts ascending (while OUT14 is OFF). If the signal turns OFF in the middle, the ram stops and ascends, and returns a “Stop in Middle” error. This is the same operation as the manual operation with the two start switches.

The following sequence assumes that the IN2 (Error Stop), IN3 (Descent Lock), IN4 (Loading Program No.), IN12 (Return to Work Home Position), and IN13 (Reset) are set to OFF.

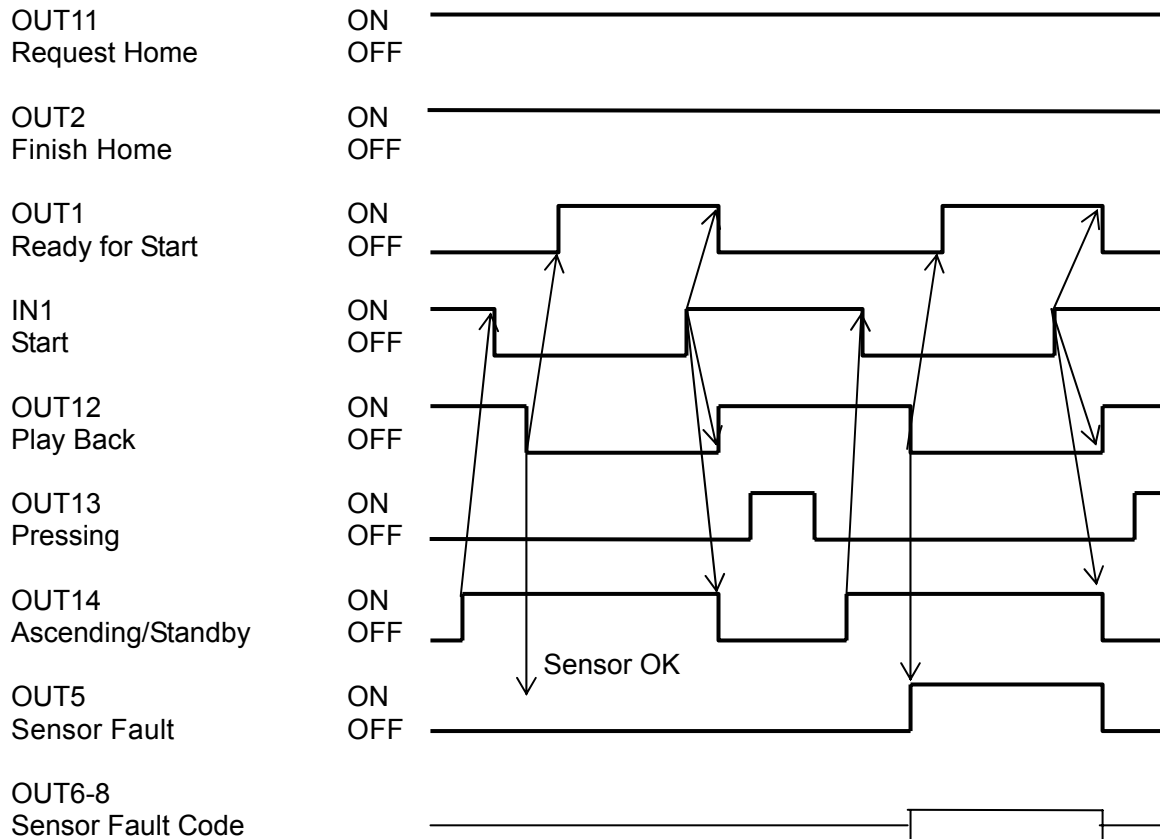

Reference:

Even if there is a sensor fault, the ram can start with the Start (IN1) signal if the Ready for Start (OUT1) signal is ON. By turning the Reset (IN13) signal ON, the error alarm and the Sensor Fault (OUT5-8) signals can be set to OFF.

● **At Start: OUT4 (Program Number Error)**

If the Electro Press enters the run mode without any teaching data, the buzzer sounds and the ram does not start. Reading an unregistered program number results in an “Empty Program Number” error.

For example,

1. The program number is over the range of 1-100.
2. The program number is not registered (no teaching data).

During this error, OUT4 turns ON, but OUT9 (Error), OUT10 (Power OFF), and OUT11 (Request Home) do not turn ON.

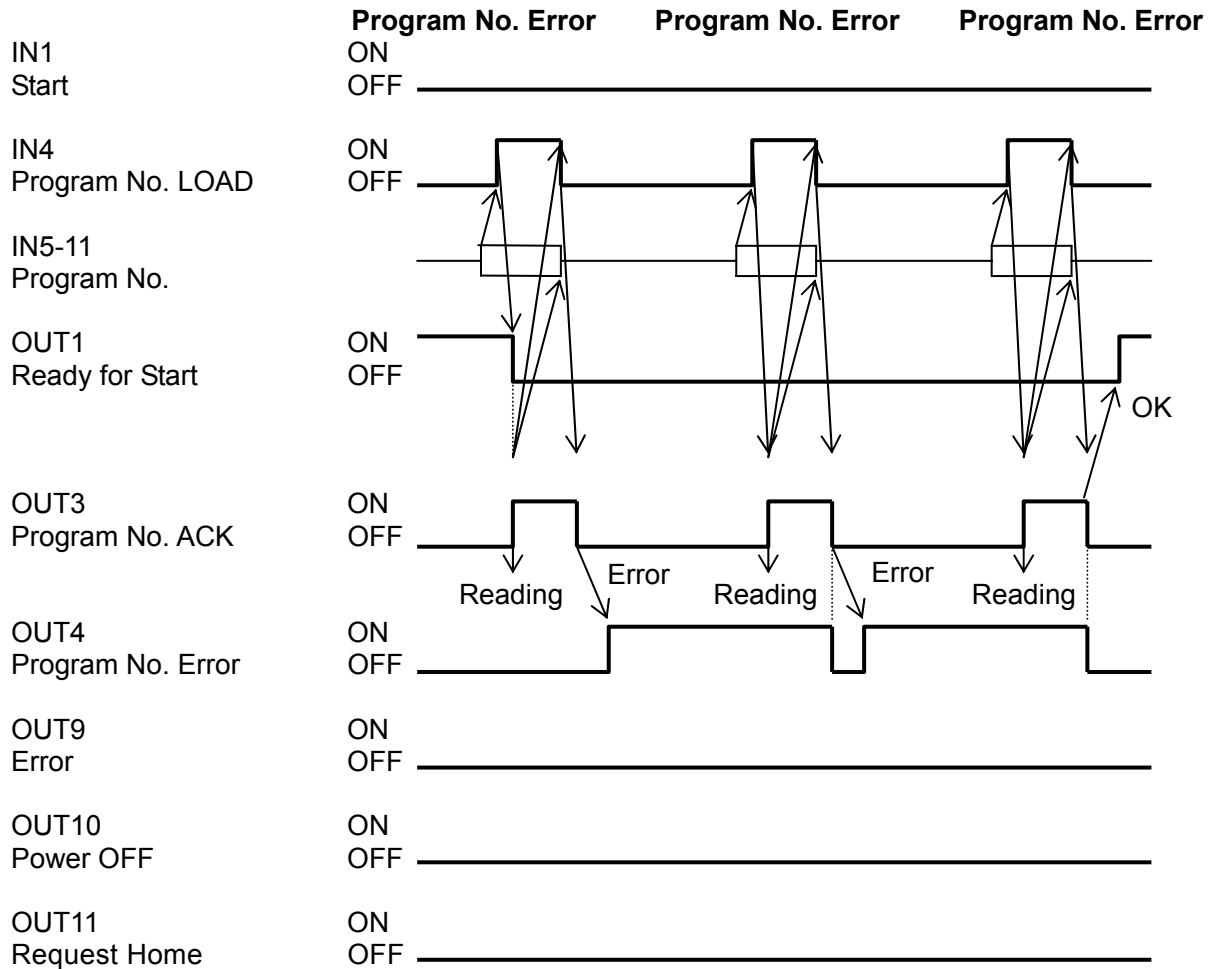

● **IN12 (Return to Work Home Position)**

This signal is used to force the ram to return to the work home position.

OUT1
Ready for Start

IN12
Return to
Work Home Position

The ram ascend to
the work home position.

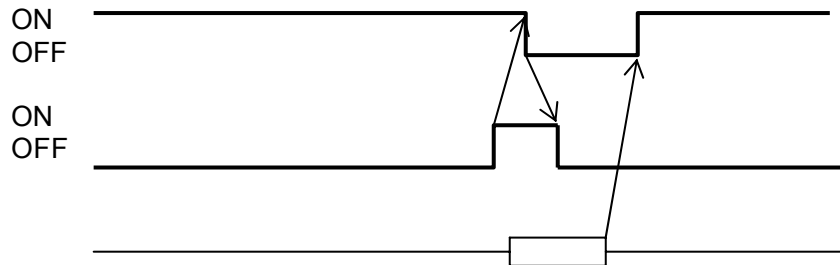

● **IN2 (Error Stop)**

The IN2 signal has a similar function to the emergency stop. It is effective during the playback and is regarded as an error (sounds an error alarm and outputs an error signal.) The ram stops on the spot and must be returned to the home position. By returning to the ram to the home position, the Electro Press recovers from the error.

The differences between the IN2 signal and the emergency stop are as follows:

1. The IN2 signal does not return an error when the ram is on standby, but the ram cannot start.
2. The IN2 signal does not cut off the power to the servomotor.

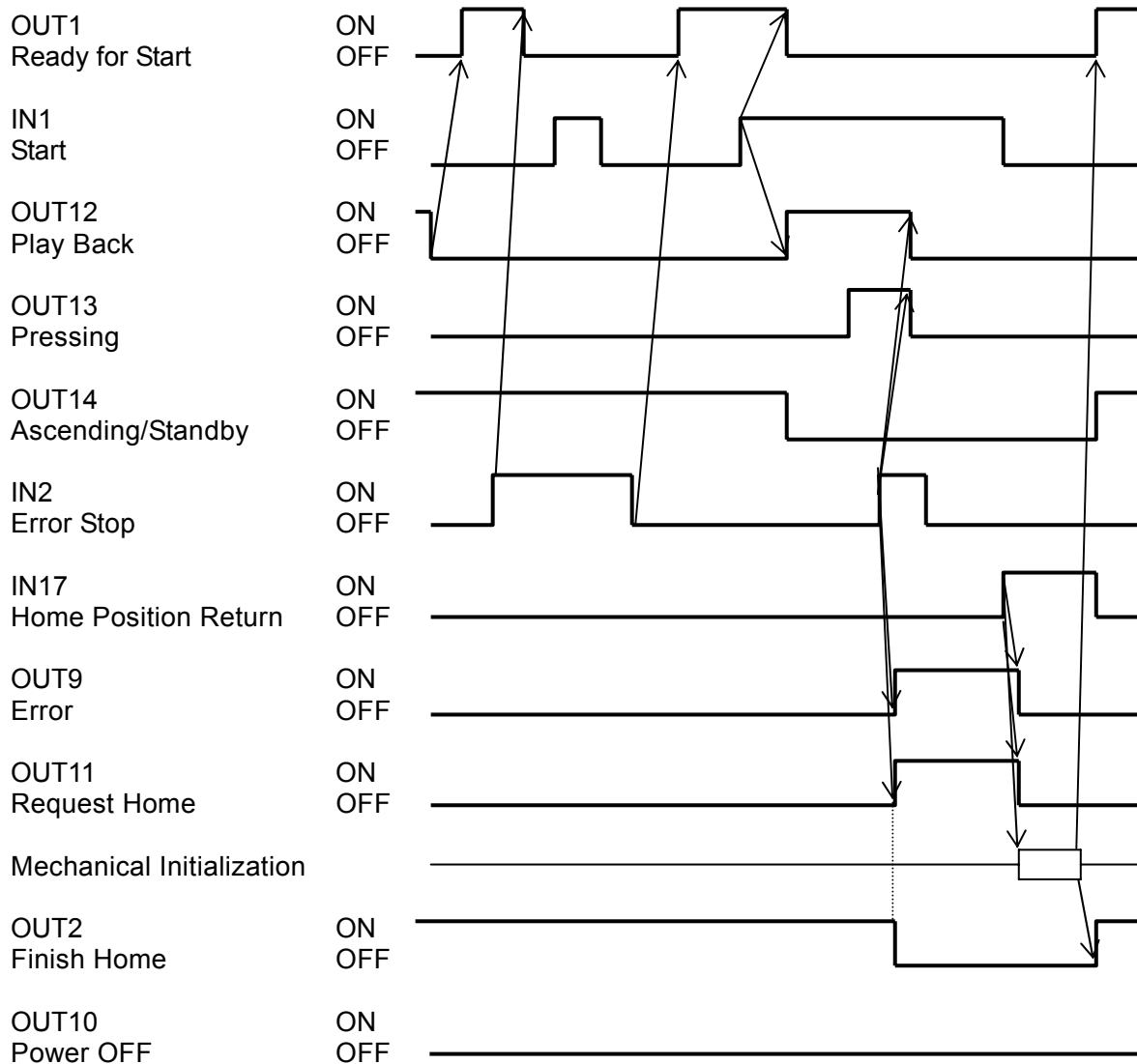

● **IN3 (Descent Lock)**

The IN3 signal locks the descending ram. It is effective while the ram is descending. If descending is stopped by the descent lock signal, it is not regarded as an error. The ram stops on the spot and the reset request is not output. The lock is reset when the IN3 signal turns OFF. (The ram ascends to work home position.) The differences between the IN2 error stop signal and the IN3 signal are as follows:

1. The IN3 signal neither outputs an error signal nor a reset request.
2. The IN3 signal is effective only when the ram is descending. (ineffective when the ram is ascending)
3. When the IN3 signal turns OFF, the ram returns to the work home position and enters the standby mode. (Home position initialization is not performed.) When the ram is on standby, it has the same function as the start prohibition. (causes no error.)

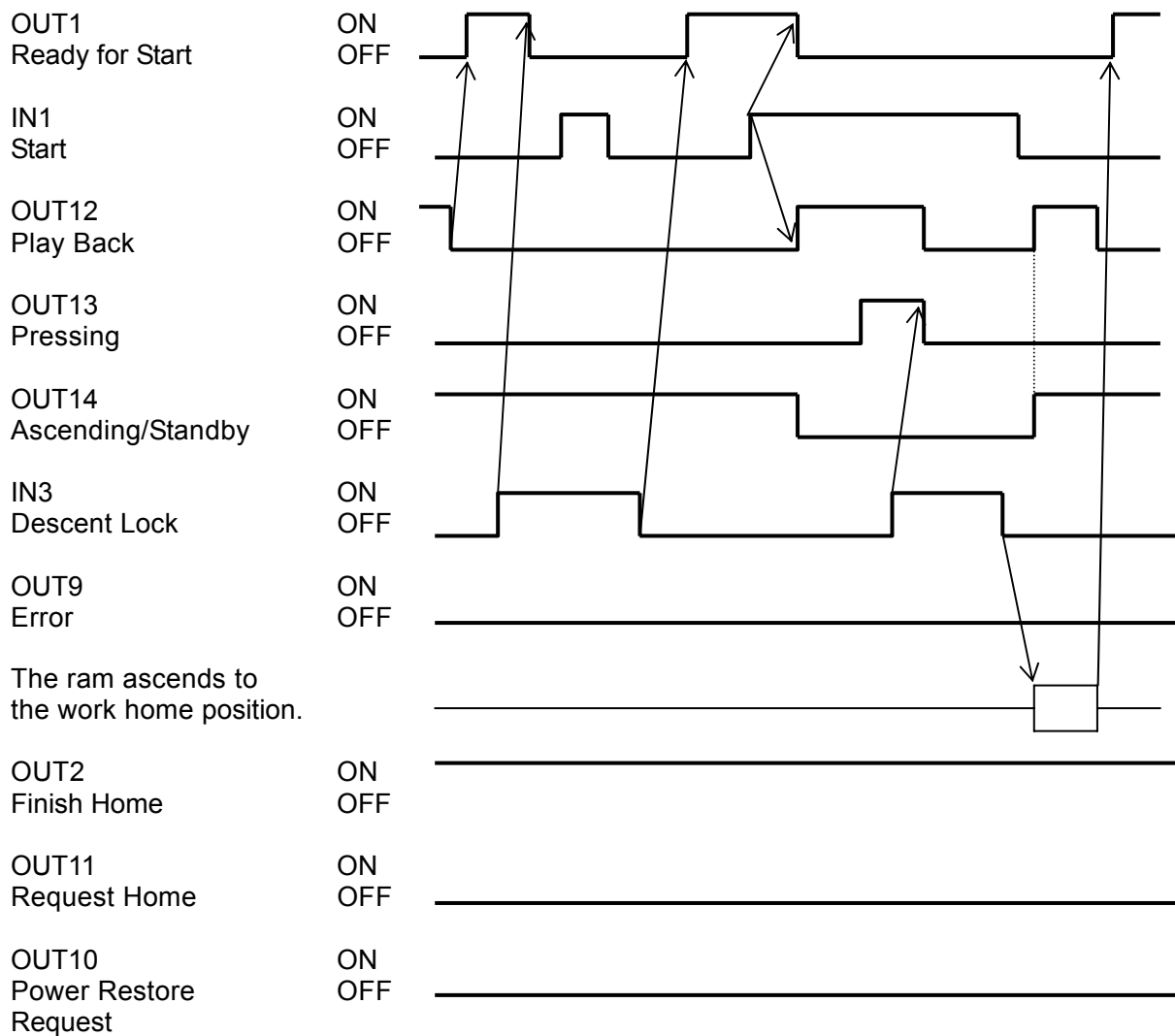

● **IN14 (Stop Pressing)**

The IN14 signal is used to stop the ram pressing temporarily. It is effective when the ram is pressing. The ram stops on the spot when this signal comes ON and restarts pressing when this signal turns OFF.

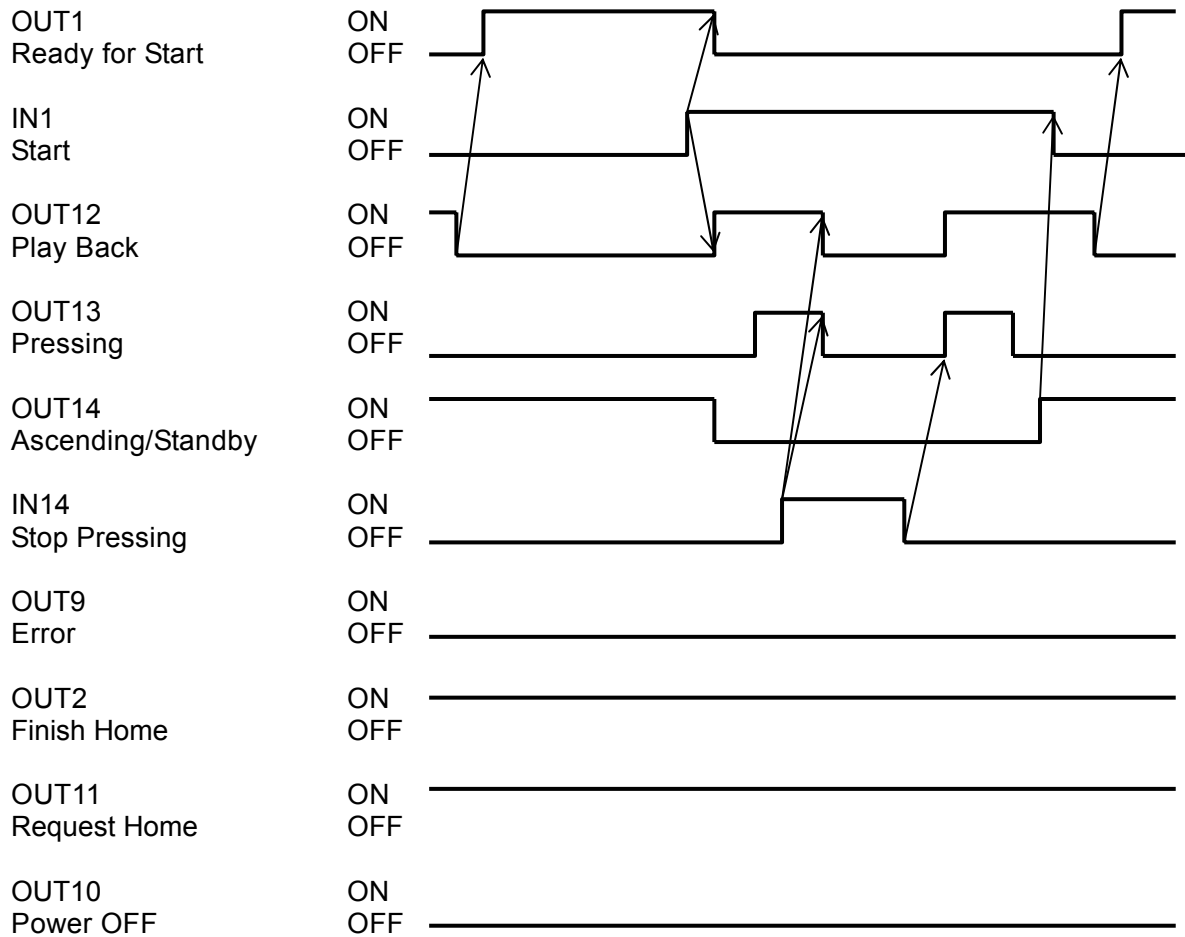

● **IN15 (Stop in Middle)**

When the IN15 signal turns ON during pressing, the ram stops immediately. If the ram is stopped, the ram returns to the work home position when this signal turns ON.

This signal is effective only when the ram is pressing or stopped after pressing. It is ineffective when the ram is on standby, approaching, and ascending.

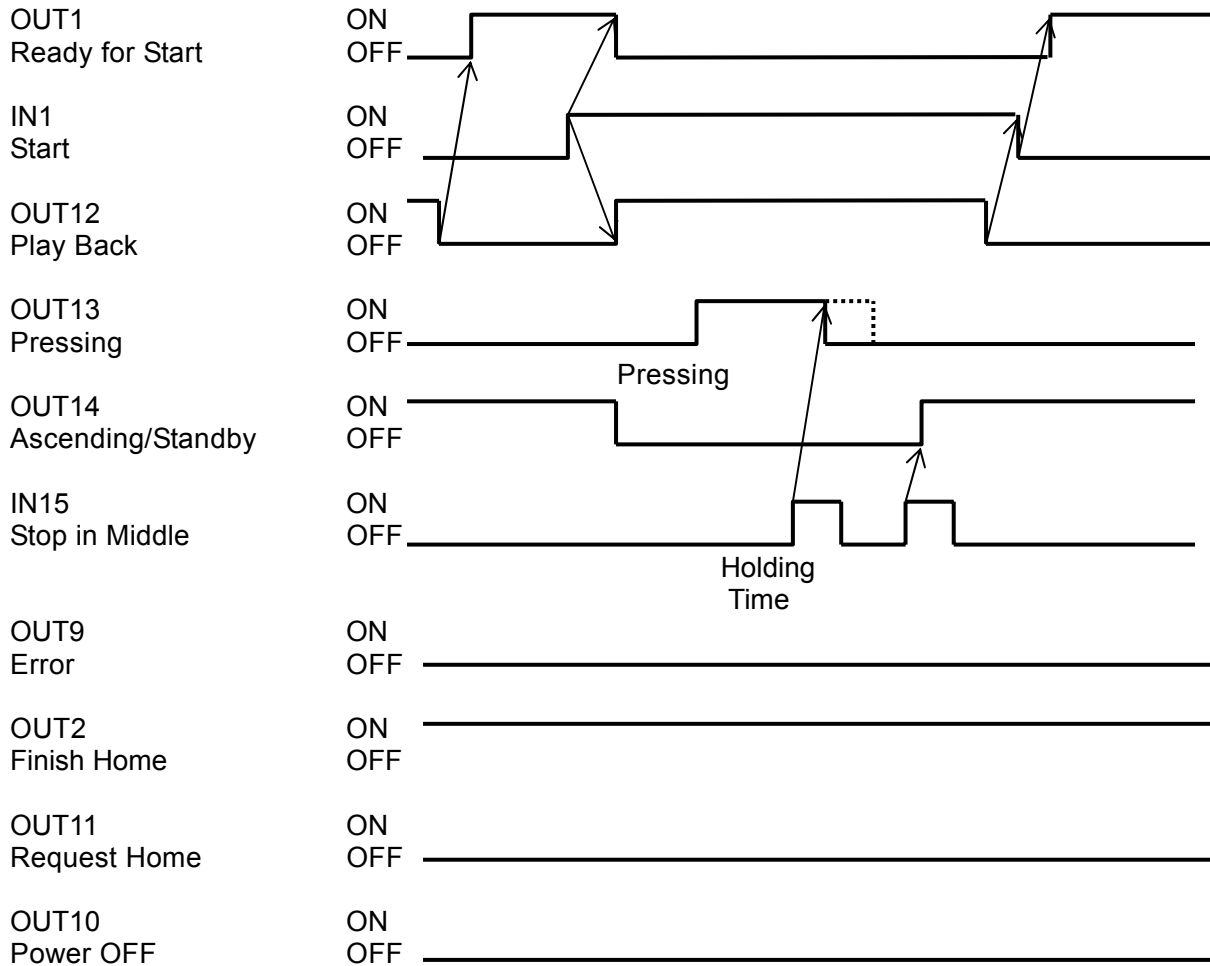

● **OUT12 (Operating in Progress), OUT13 (Pressing in Progress)**

The OUT14 (Ascending/Standby) signal indicates the current running state and position of the ram. The OUT1 (Ready for Start) signal indicates that the ram is not only at the work home position but also ready to start soon after the start up. The functions of these two signals are slightly different from those of other signals. The OUT2 (Finish Home) signal remains ON after completing the home position return.

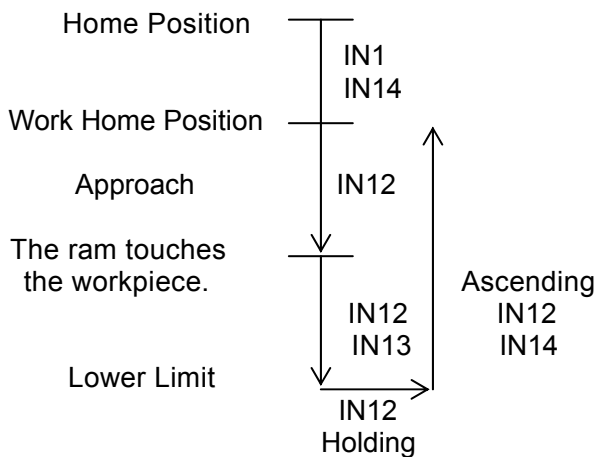
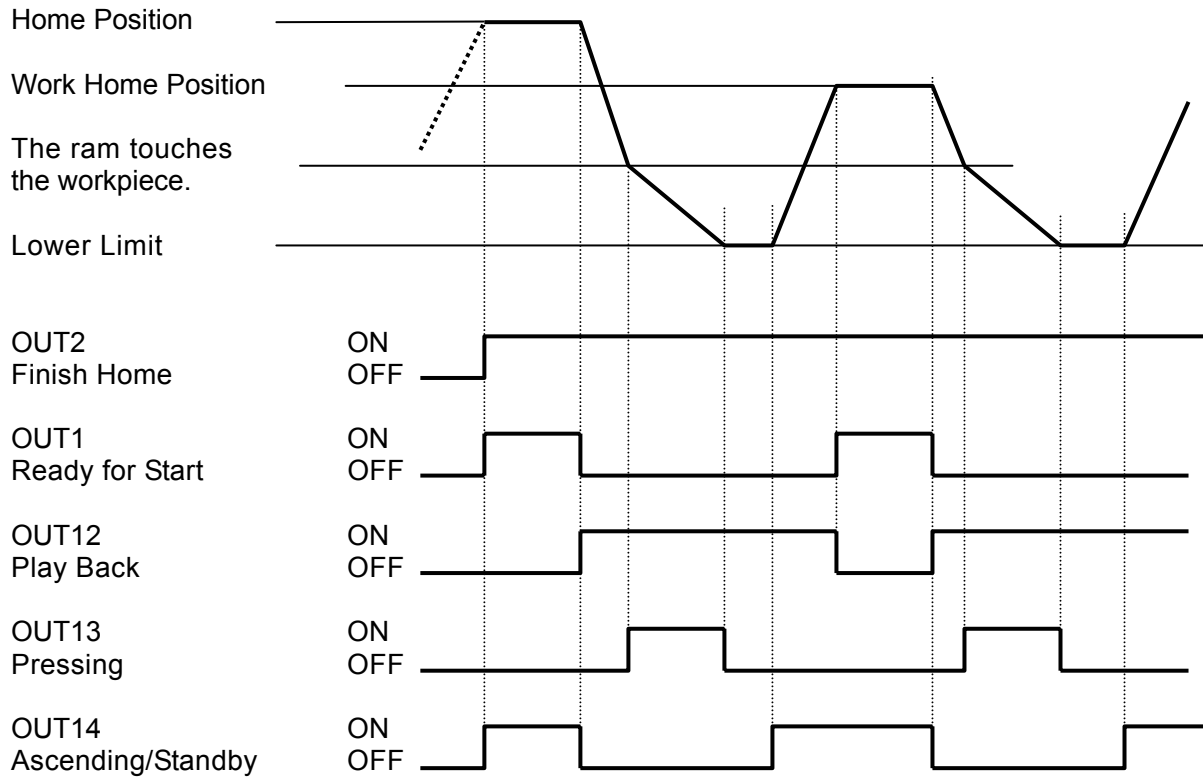

● **IN16 (Sampling Signal), OUT16 (Sampling Signal ACK)**

Using the IN16 input and OUT16 output signals, the playback data (time, position, load) can be sampled via external devices.

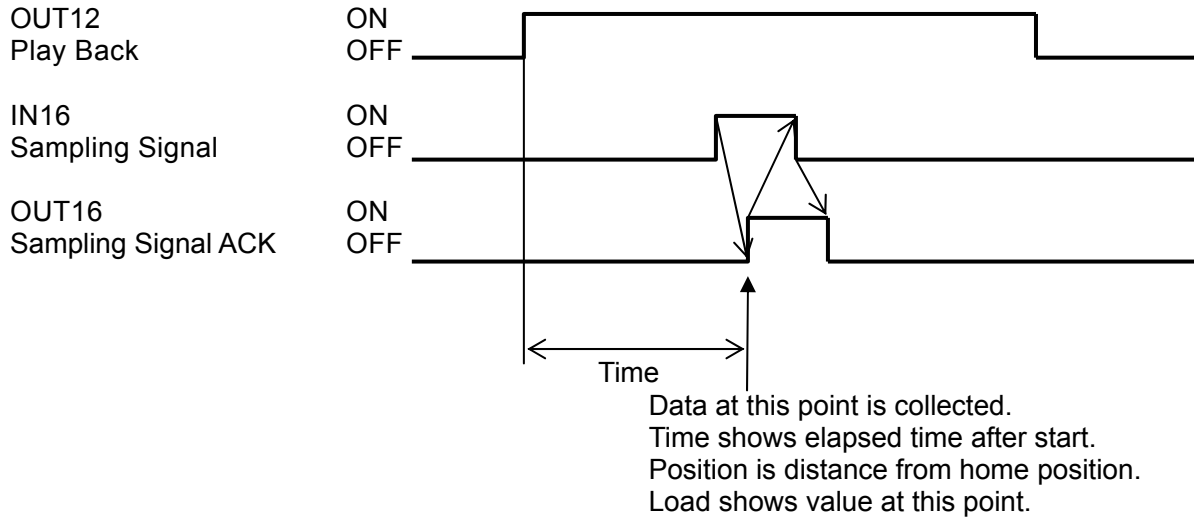

The sampled data will be displayed on the LCD after operation. If you are collecting the control information via a PC, the report will be sent out as sample data to the PC. Five samples can be collected in one cycle of operation.

● **Emergency Stop (by area sensor)/Error Stop, Request Home**

If an Emergency Stop by the area sensor or “Stop in Middle” error by Error Stop occur, the Error (OUT9) and Request Home (OUT11) signals turn ON.

Thereafter, the operator has to remove the cause of error (release the stop and emergency stop signals) and input the Home Position Return (IN17) signal. The ram returns to the home position and is ready to start.

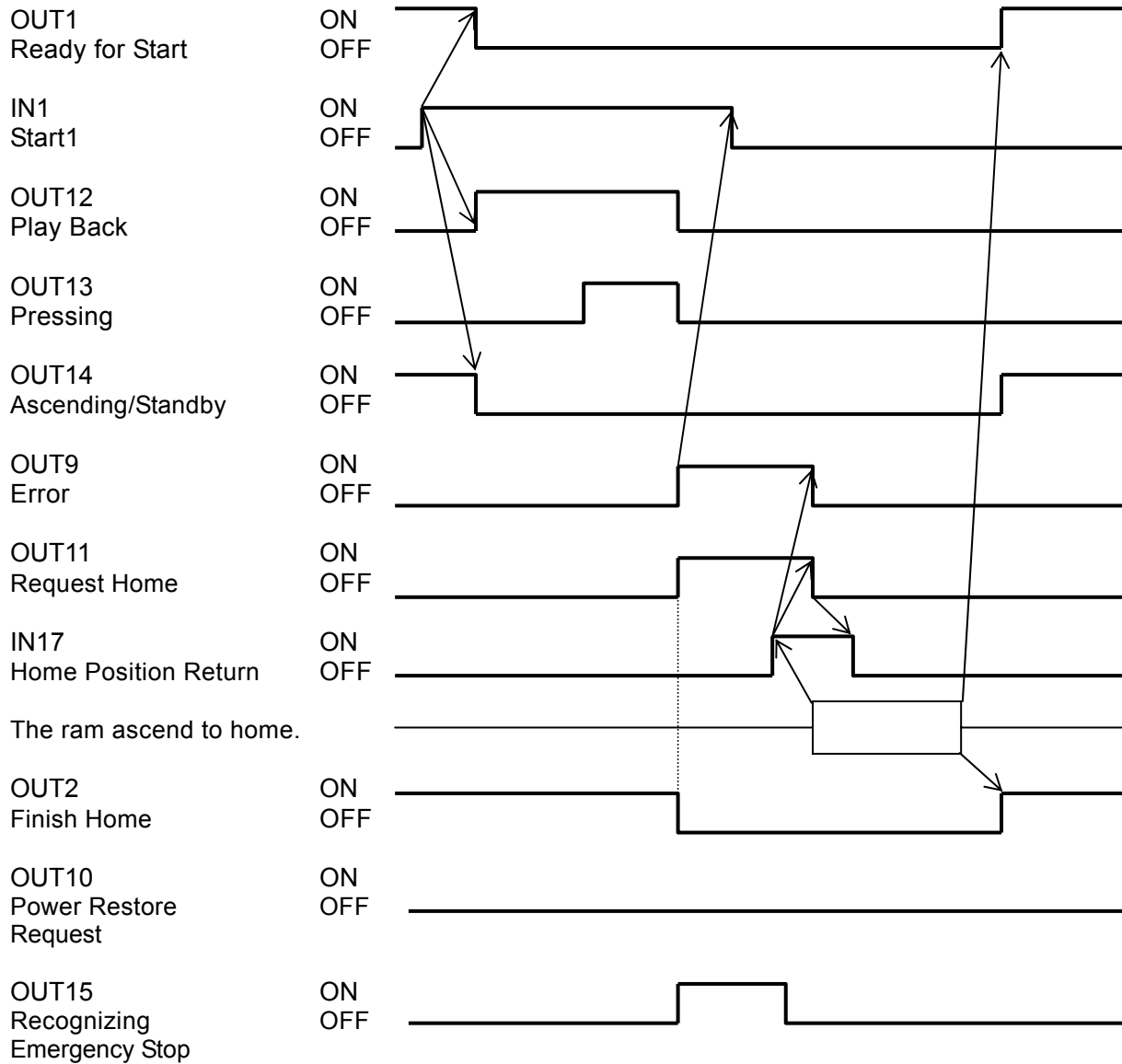

● **Error (OUT9), Power OFF (OUT10)**

If an error is caused by the servomotor tripping, or a hardware or mechanical fault, the ram is unable to restart. In such cases, the Power OFF (OUT10) and the Error (OUT9) signals turn ON. The operator has to turn off the power.

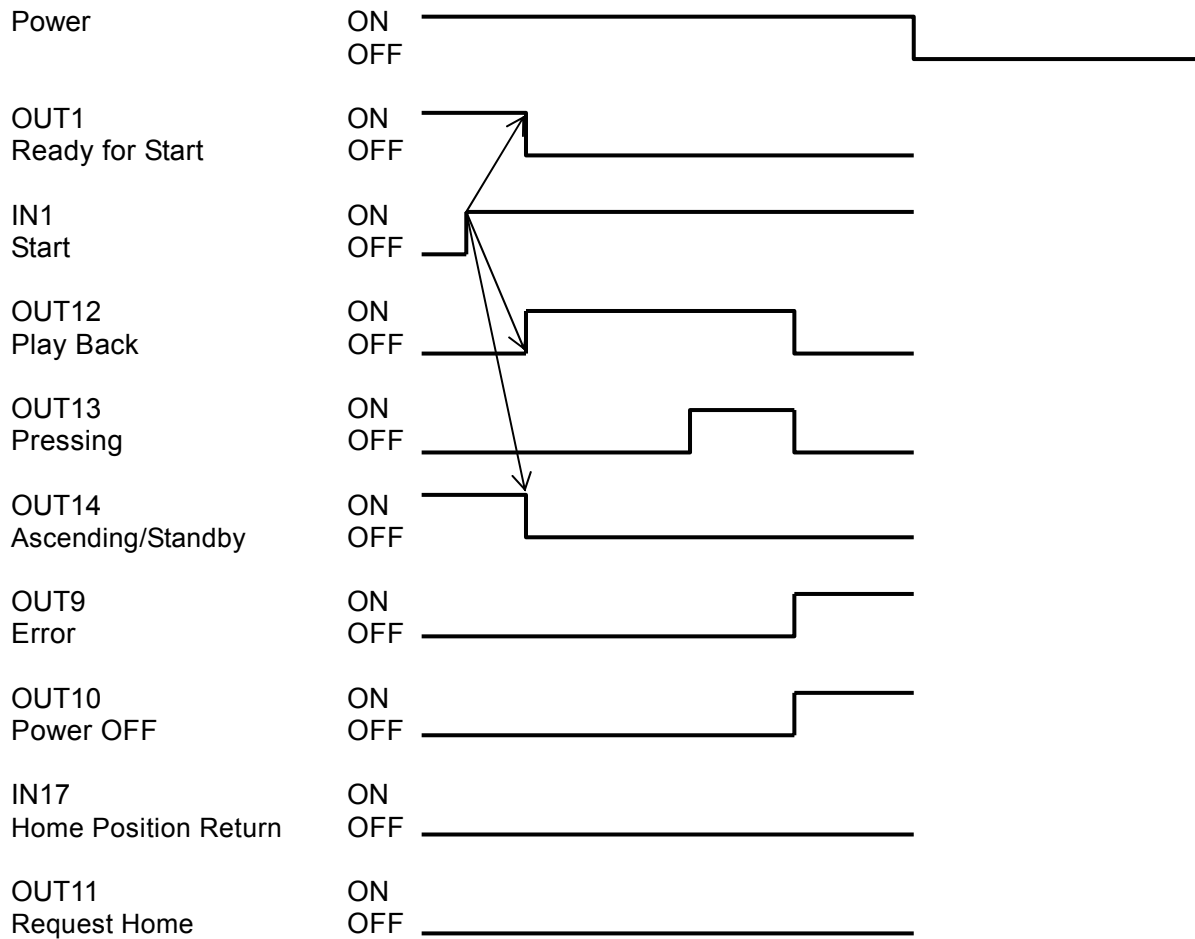

3-12 I/O-SYS Connection

Input

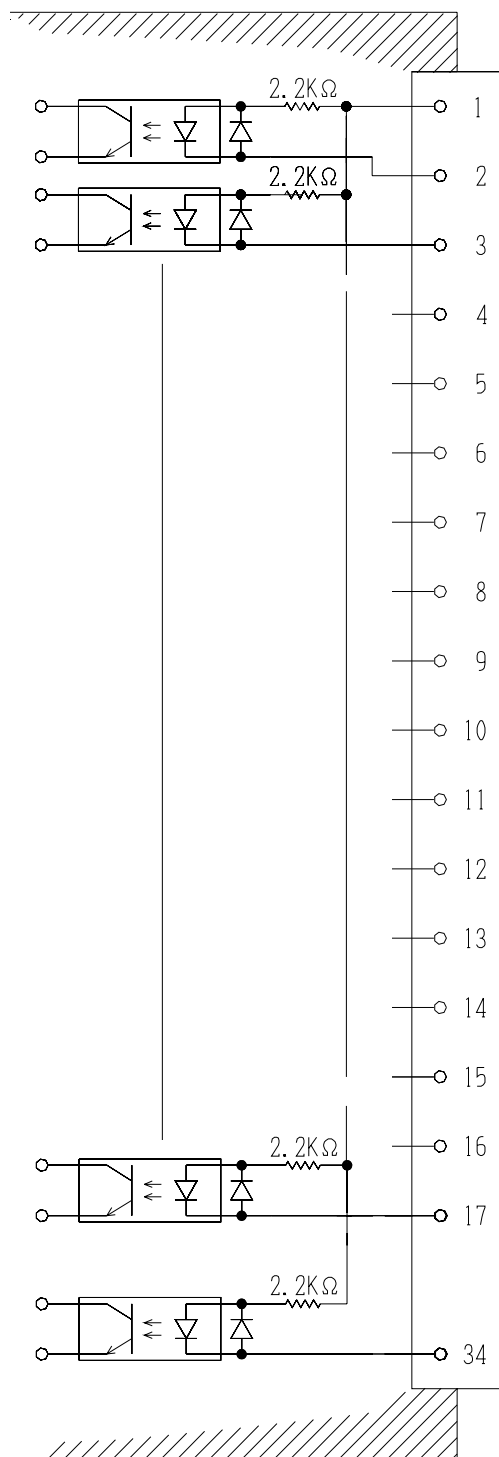

Pin No.	Terminal	Standard Specification	Special Specification
1	COM+	DC12V - 24V	DC12V - 24V
2	IN 1	Start	General-purpose
3	IN. 2	Error Stop	General-purpose
4	IN 3	Descent Lock	General-purpose
5	IN 4	Program No. LOAD	General-purpose
6	IN 5	Program No. B0	General-purpose
7	IN 6	Program No. B1	General-purpose
8	IN 7	Program No. B2	General-purpose
9	IN 8	Program No. B3	General-purpose
10	IN 9	Program No. B4	General-purpose
11	IN 10	Program No. B5	General-purpose
12	IN 11	Program No. B6	General-purpose
13	IN 12	Return to Work Home Position	General-purpose
14	IN 13	Reset	General-purpose
15	IN 14	Stop Pressing	General-purpose
16	IN 15	Stop in Middle	General-purpose
17	IN 16	Sampling Signal	General-purpose
34	IN 17	Home Position Return (Motor power ON)	Home Position Return (Motor power ON)

- Please provide an external power source (DC12V – DC24V, 0.5 Amp. minimum). The wiring should be connected between COM+ and COM-.

Output

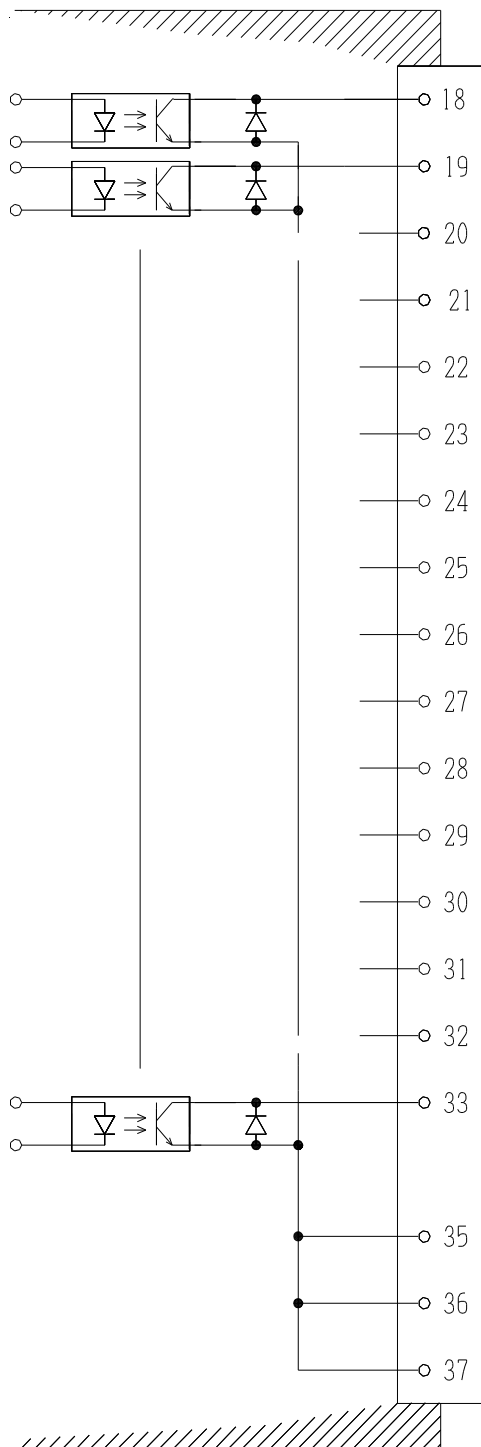

Pin No.	Terminal	Standard Specification	Special Specification
18	OUT 1	Ready for Start	General-purpose
19	OUT 2	Finish Home	General-purpose
20	OUT 3	Program No. ACK	General-purpose
21	OUT 4	Program No. Error	General-purpose
22	OUT 5	Sensor Fault	General-purpose
23	OUT 6	Sensor Fault (U/L)	General-purpose
24	OUT 7	Sensor Fault JB0	General-purpose
25	OUT 8	Sensor Fault JB1	General-purpose
26	OUT 9	Error	General-purpose
27	OUT 10	Power OFF	General-purpose
28	OUT 11	Request Home	General-purpose
29	OUT 12	Play Back	General-purpose
30	OUT 13	Pressing	General-purpose
31	OUT 14	Ascending/ Standby	General-purpose
32	OUT 15	Recognizing Emergency Stop	General-purpose
33	OUT 16	Sampling Signal ACK	General-purpose
35	COM-	GND	GND
36	COM-	GND	GND
37	COM-	GND	GND



Caution

Ensure that the output current is 100mA or less and the voltage delivered to the output terminal is 50V or less. Otherwise, the driver may be damaged.



Caution

When you apply voltage between COM- and OUT1 – OUT16, check the polarity of the voltage before applying. Otherwise, the driver may be damaged.

3-13 I/O-SYS Cable (Optional)

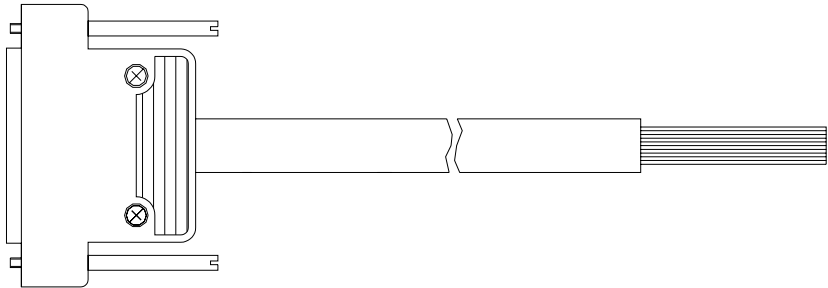

Pin No.	Color of Insulator	Spiral Mark	Pin No.	Color of Insulator	Spiral Mark
1	Black		21	Red	White
2	White		22	Red	Black
3	Red		23	Red	Green
4	Green		24	Red	Blue
5	Yellow		25	Green	White
6	Brown		26	Green	Black
7	Blue		27	Green	Red
8	Gray		28	Green	Blue
9	Orange		29	Yellow	White
10	Pink		30	Yellow	Black
11	Light blue		31	Yellow	Red
12	Violet		32	Yellow	Green
13	White	Black	33	Yellow	Blue
14	White	Red	34	Brown	White
15	White	Green	35	Brown	Black
16	White	Blue	36	Brown	Red
17	Black	White	37	Brown	Green
18	Black	Red		Brown	Blue
19	Black	Green		Blue	White
20	Black	Blue		Blue	Black

4. I/O-1 (Optional)

4-1 I/O-1 Connector

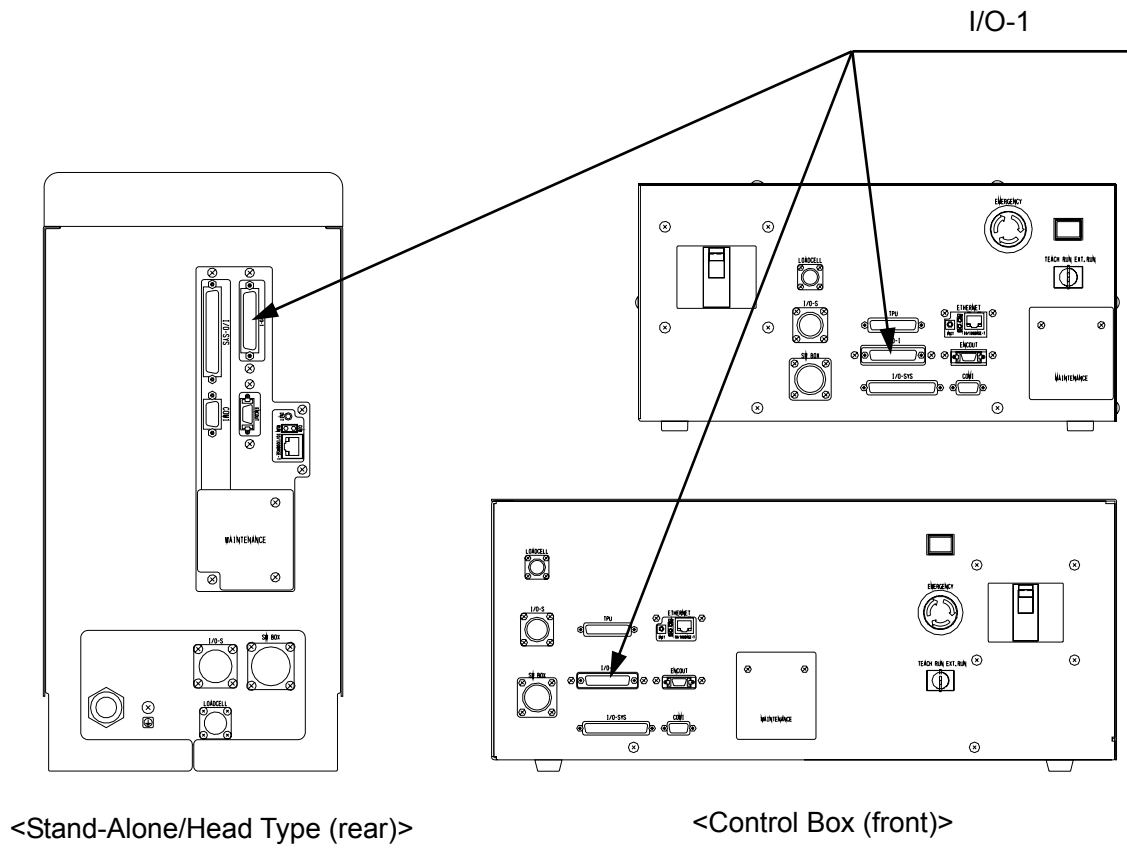

<Pin No>

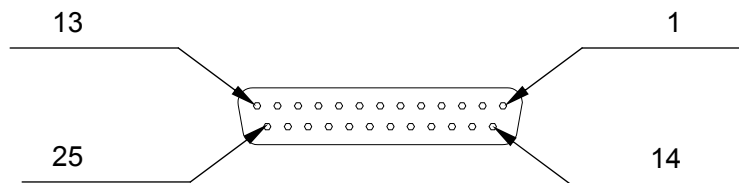

- * On the Electro Press
- * On the control box

4-2 Function Assignment

Photo coupler output 8, input 8

	Name	Functions	PIN No.
Input	#genIn1	Free	1
	#genIn2	Free	2
	#genIn3	Free	3
	#genIn4	Free	4
	#genIn5	Free	5
	#genIn6	Free	6
	#genIn7	Free	7
	#genIn8	Free	8
Output	#genOut1	Free	9
	#genOut2	Free	10
	#genOut3	Free	11
	#genOut4	Free	12
	#genOut5	Free	13
	#genOut6	Free	14
	#genOut7	Free	15
	#genOut8	Free	16

	Name	Functions	PIN No.
	COM+	24V Power Supply	17
	COM+	24V Power Supply	18
	COM+	24V Power Supply	19
	COM+	24V Power Supply	20
	COM-	GND	21
	COM-	GND	22
	COM-	GND	23
	COM-	GND	24
		NC	25

4-3 I/O-1 Input Signal (Sink Input)

Input signals are active when the photo coupler is ON.

Internal Power Supply

When an internal power supply is used, the input pin and the COM- pin below should be shorted as shown.

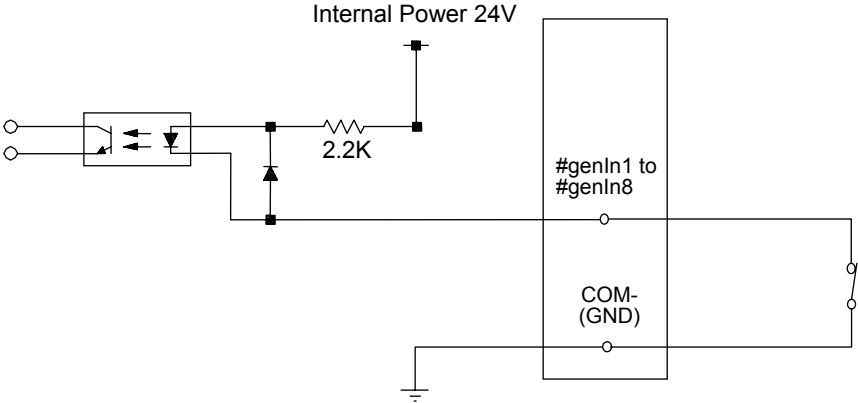

External Power Supply

When an external power supply is used, the input pin and external power ground below should be ON as shown.

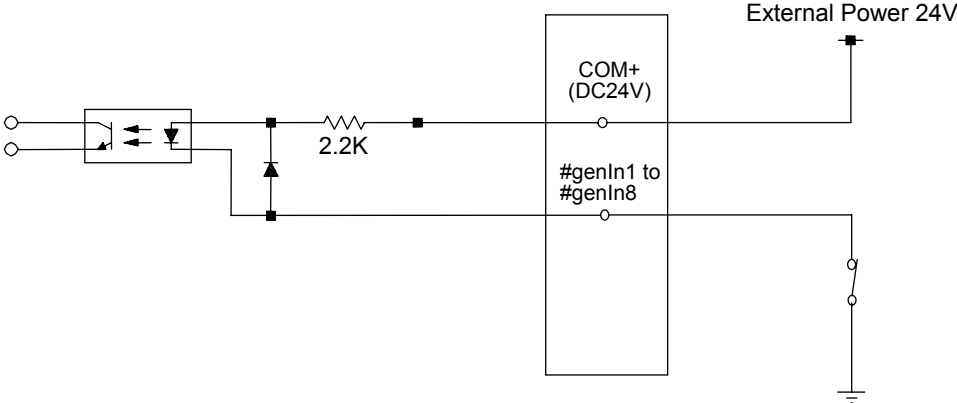

4-4 I/O-1 Output Signal (Sink Output)

Internal Power Supply

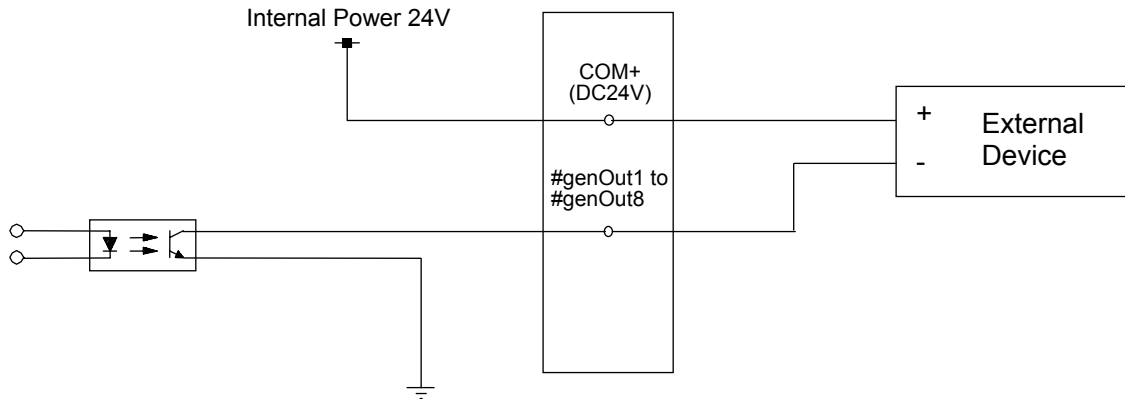

External Power Supply

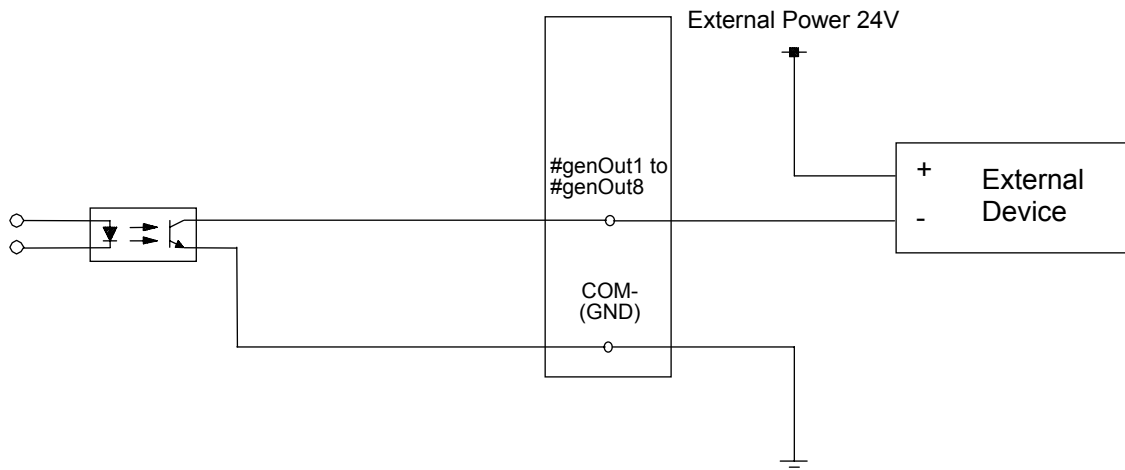

4-5 I/O-1 Output Capacity (Sink Output)

For both the internal power supply and external power supply, use rated voltage not more than the following.

- 100 mA for 1 pin (DC24V)

For the internal power supply, use rated voltage not more than the following.

- DC24V, 2A (Total of the I/O-SYS and I/O-1)

4-6 I/O-1 Circuit Diagram (Sink Input/Output)

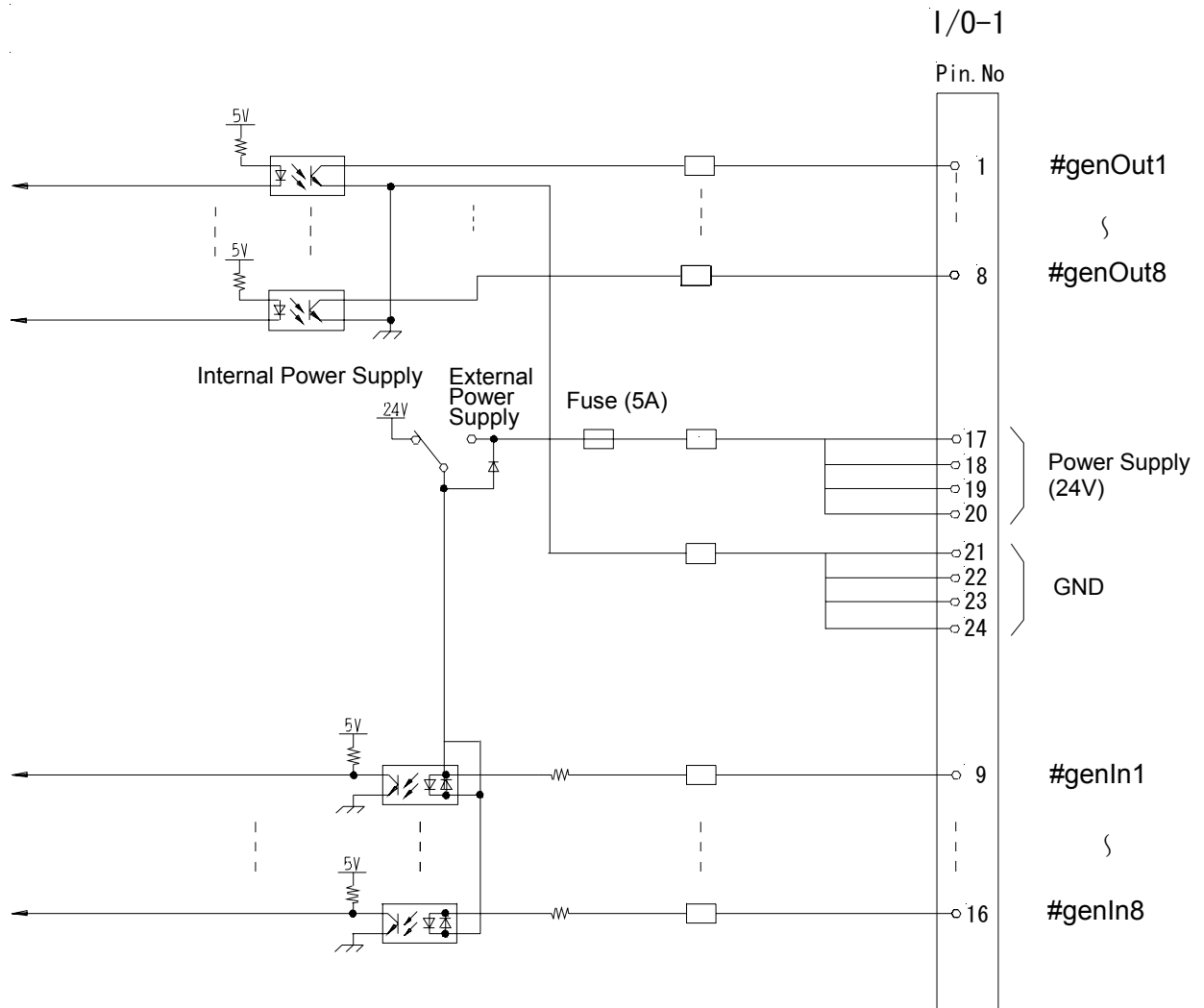

4-7 I/O-1 Input Signal (Source Input)

Input signals are active when the photo coupler is ON.

Internal Power Supply

When an internal power supply is used, the input pin and the COM+ pin below should be shorted as shown.

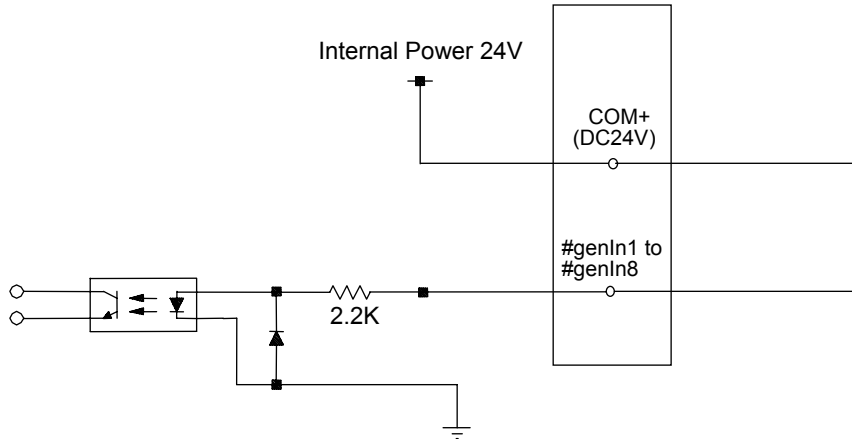

External Power Supply

When an external power supply is used, the input pin and external power below should be ON as shown.

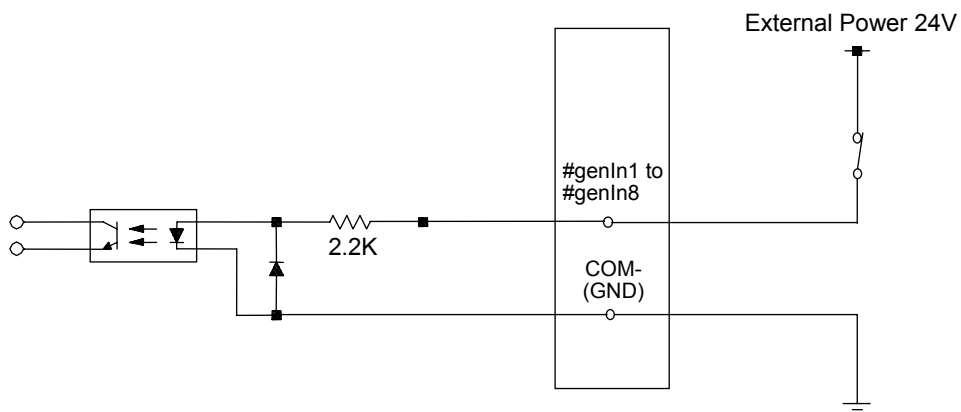

4-8 I/O-1 Output Signal (Source Output)

Internal Power Supply

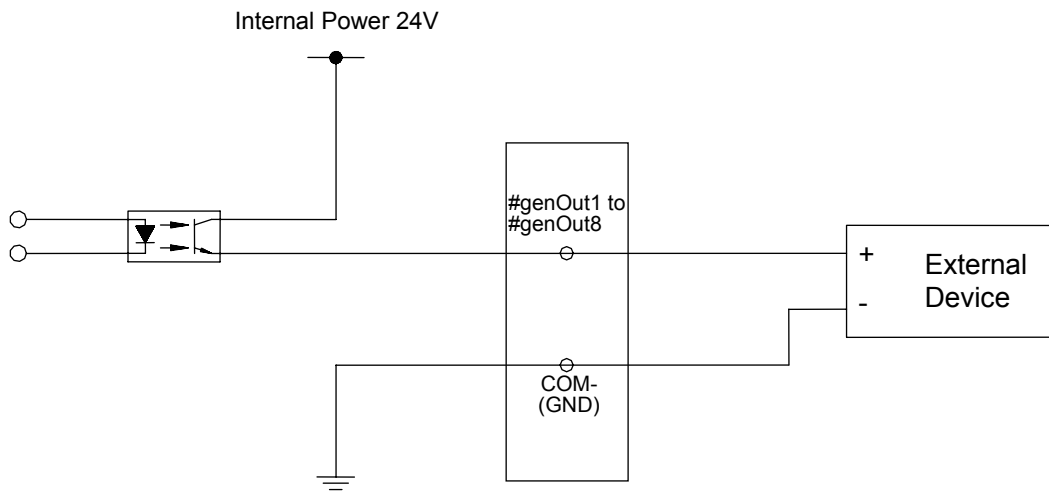

External Power Supply

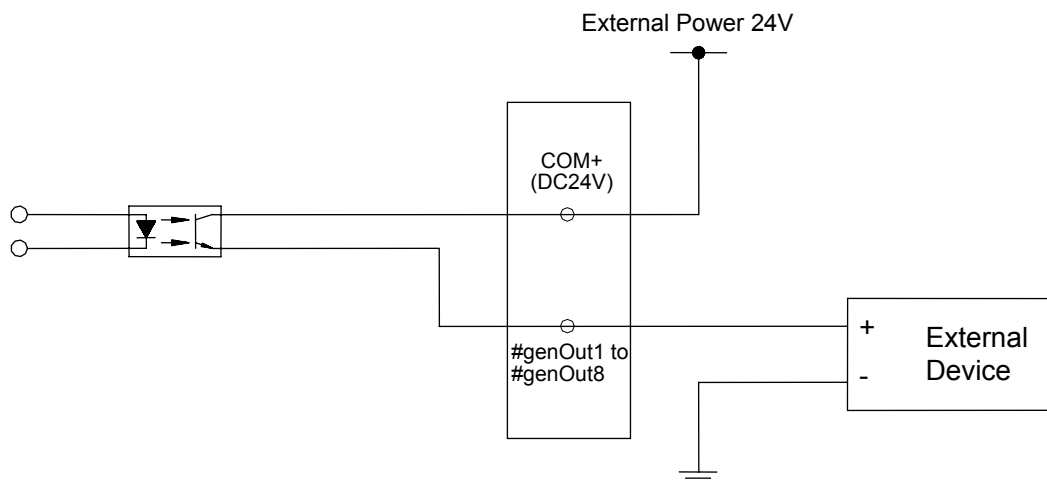

4-9 I/O-1 Output Capacity (Source Output)

For both the internal power supply and external power supply, use rated voltage not more than the following.

- 100 mA for 1 pin (DC24V)

For the internal power supply, use rated voltage not more than the following.

- DC24V, 2A (Total of the I/O-SYS and I/O-1)

4-10 I/O-1 Circuit Diagram (Source Input/Output)

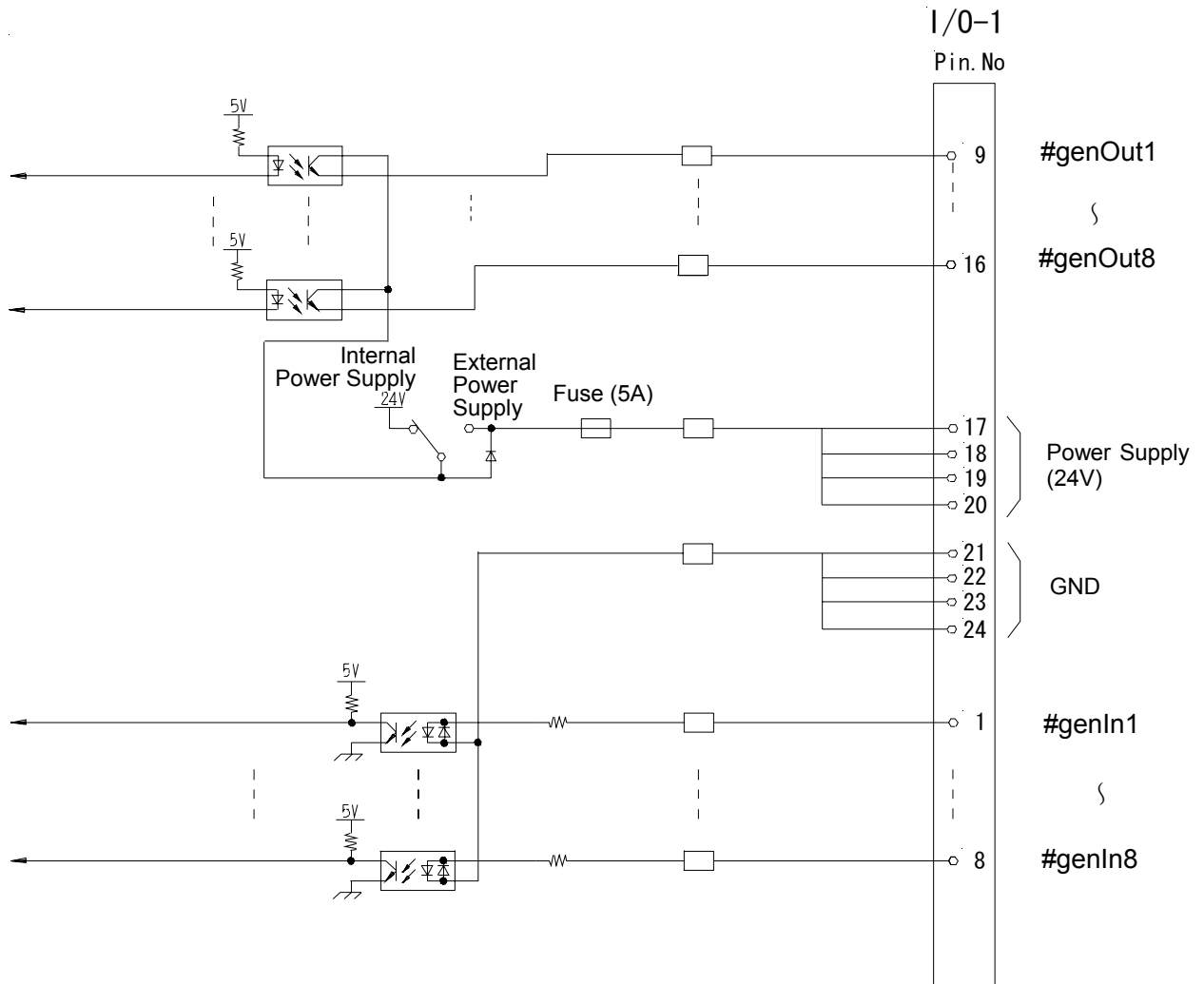

4-11 Switching I/O-1 Power Supply

Turn OFF the Electro Press and remove the cover on the rear body (Stand-alone/Head type) or the cover on the control box (front) (Unit type) to adjust the following switches.

Switch	Display	IN	EXT
I/O-1 Power Selection Switch		Internal Power Supply	External Power Supply

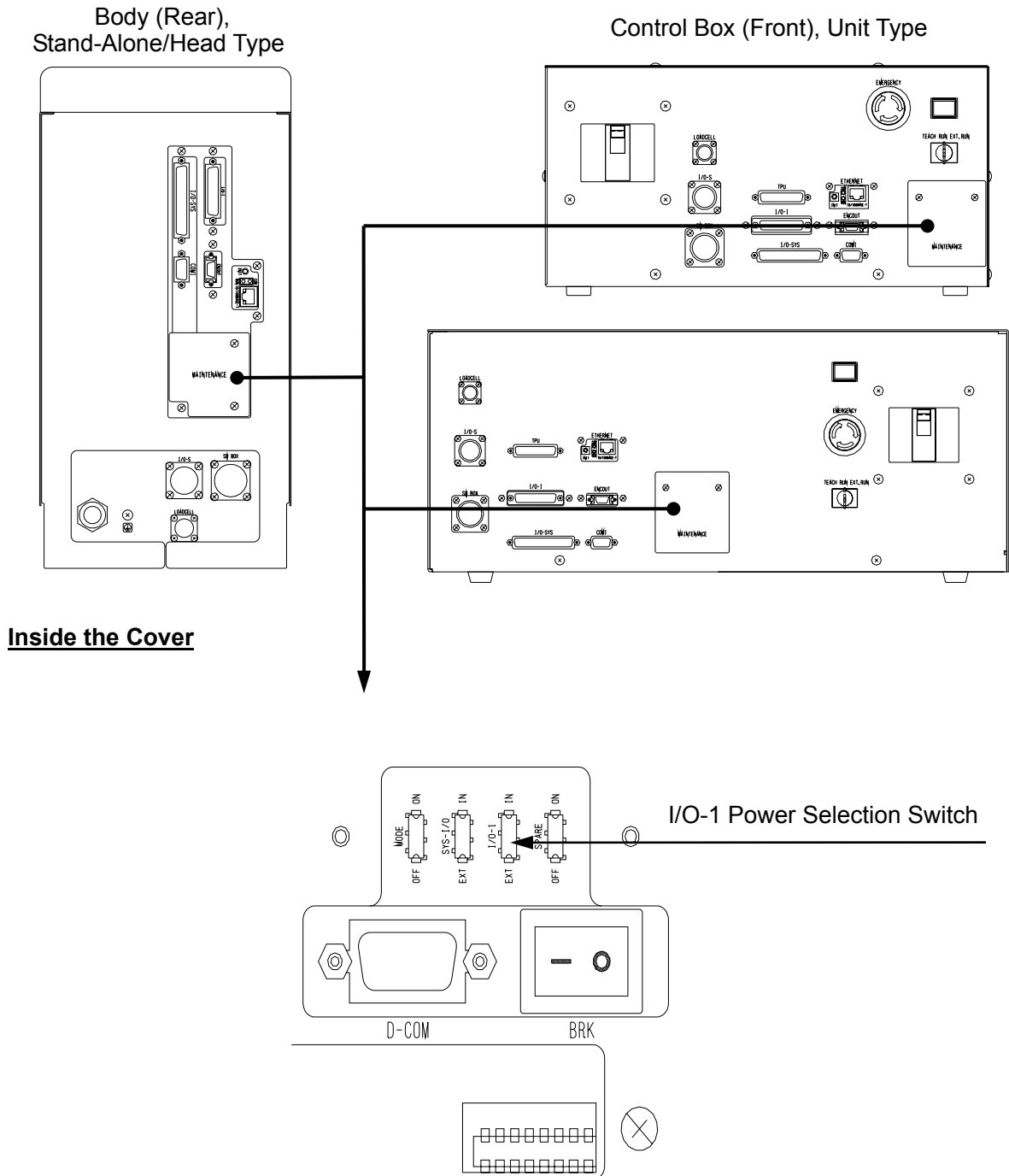

5. I/O-S

5-1 I/O-S Connector

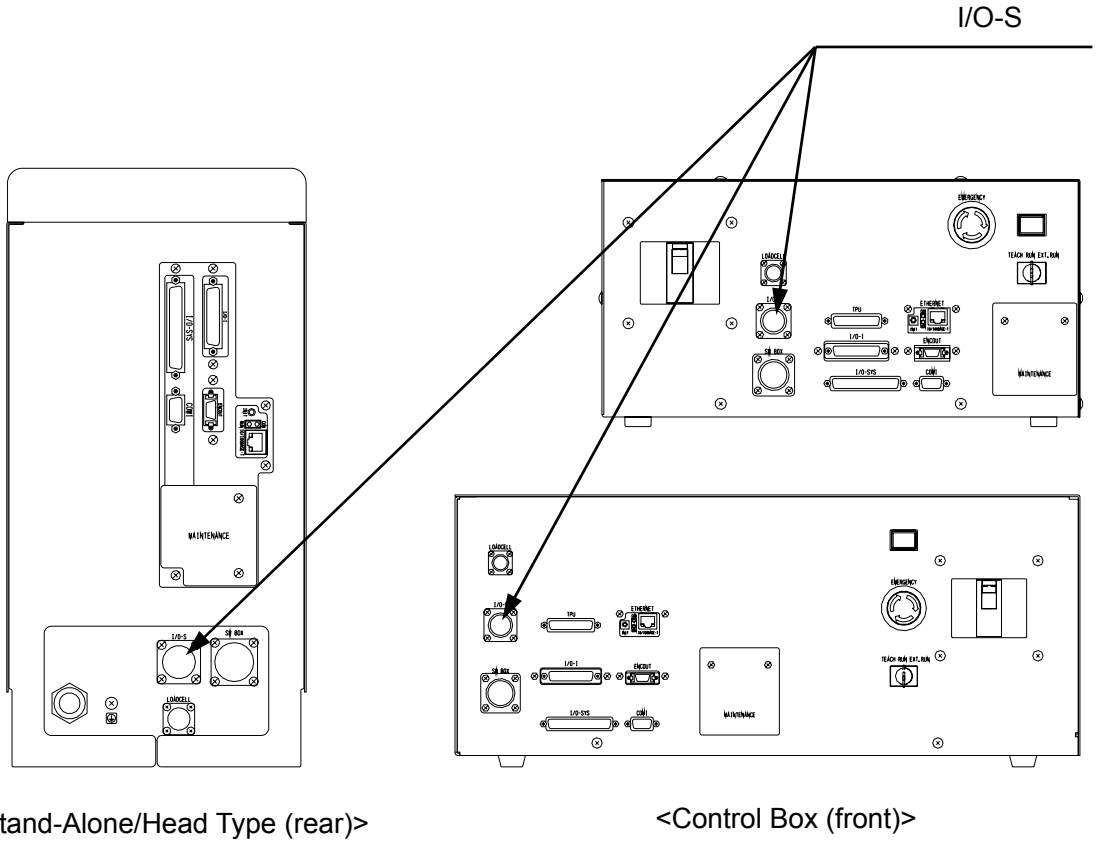

<Pin No.>

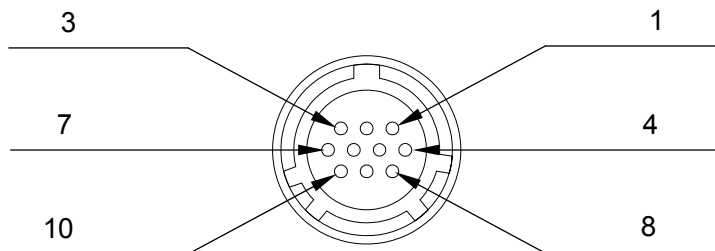

- * On the Electro Press
- * On the control box

5-2 I/O-S Pin Assignment

The I/O-S is an interface for attaching a door switch or area sensor.
The safety category is 3.

Pin No.	Name	Functions
1	EMG1-1	Emergency Stop 1-1 Input
2	EMG2-1	Emergency Stop 2-1 Input
3	EMG2-2	Emergency Stop 2-2 Input
4	EMG1-2	Emergency Stop 1-2 Input
5	T11	Safety relay T11
6	T12	Safety relay T12
7	T21	Safety relay T21
8	T23	Safety relay T23
9	T22	Safety relay T22
10		GND

Please see the circuit diagram on the next page.

<Example of the IO-S connection>

Connect the door switch or area sensor to the I/O-S as below.

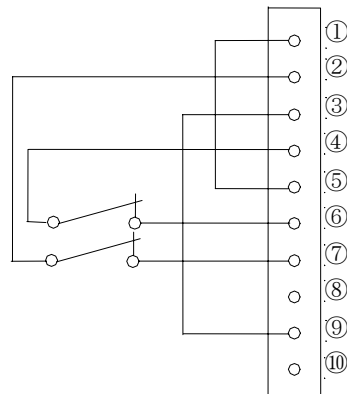

Door Switch Connection

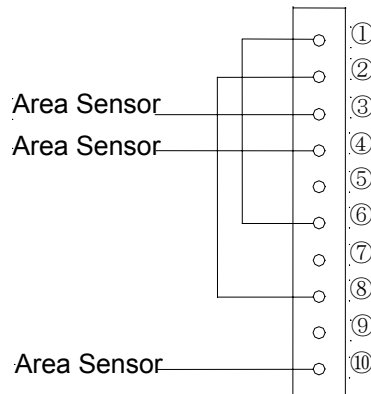

Area Sensor Connection

- Use a PNP specification area sensor. It is PNP specification only that can be connected to our safety circuit. Please note that a NPN area sensor cannot be connected.

<Safety Circuit>

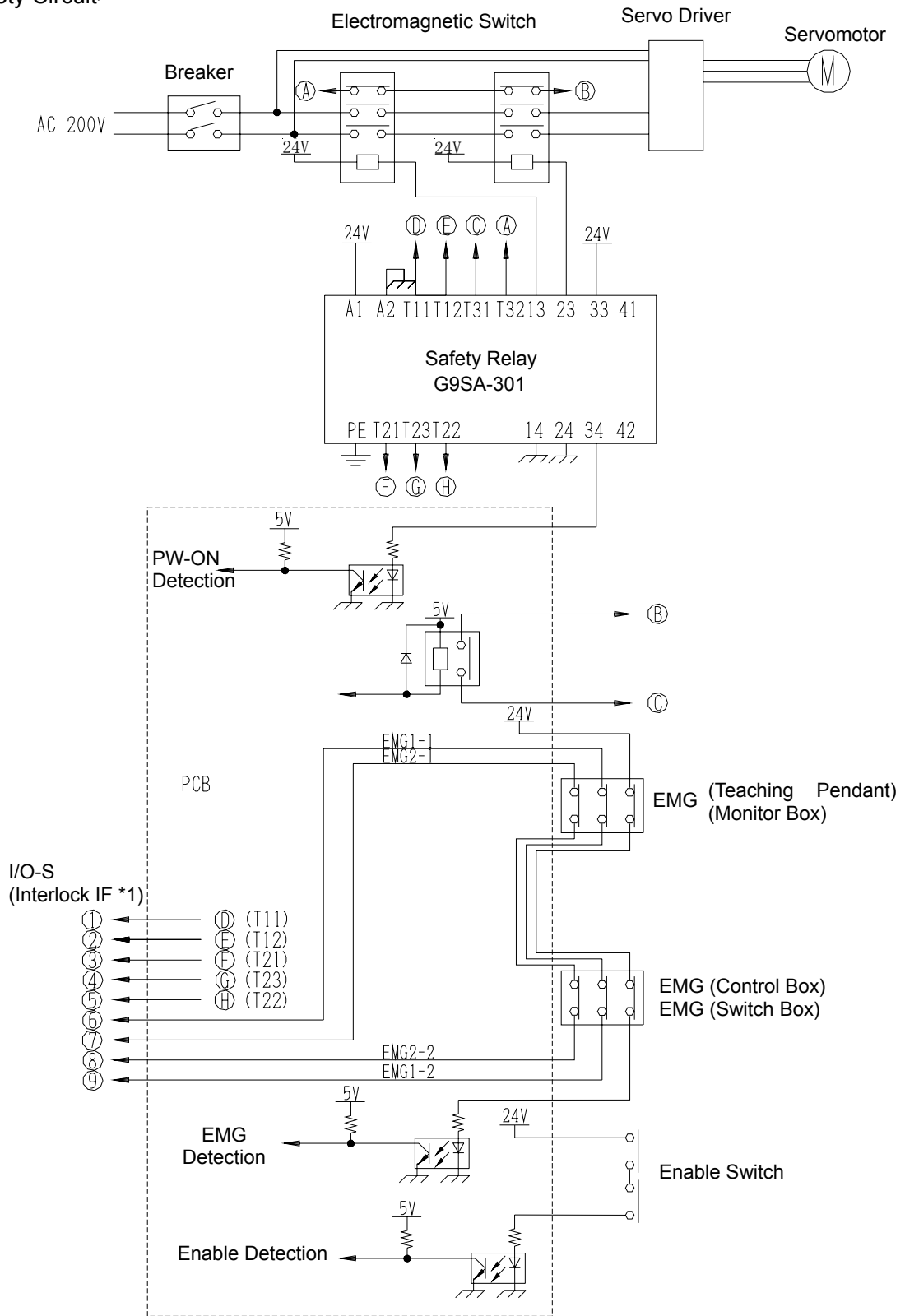

*1: Connect to the Area Sensor, Limit SW.

Safety Circuit Behavior Sequence

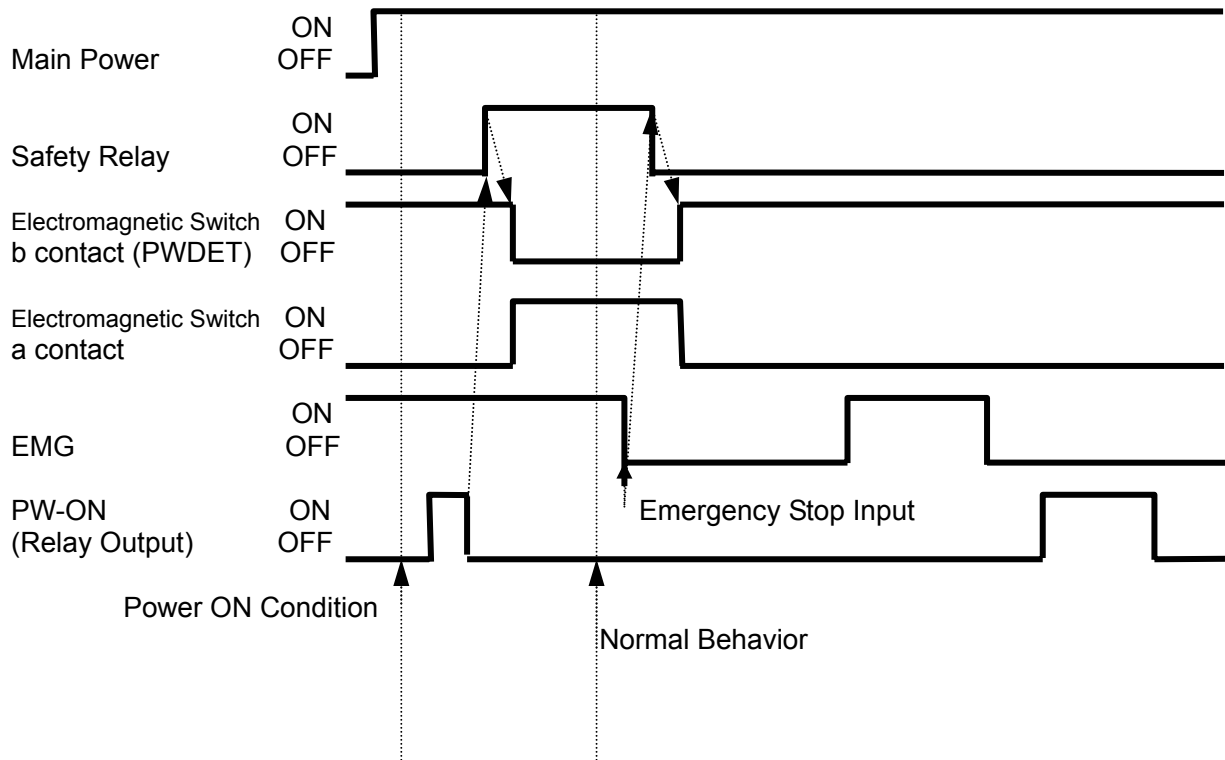

- If the electromagnetic switch or EMG is ON, it means that the contact is closed.
- EMG IS EMG (T.P), EMG (Switch BOXIF) or IO-S.

6. COM

6-1 COM Connector

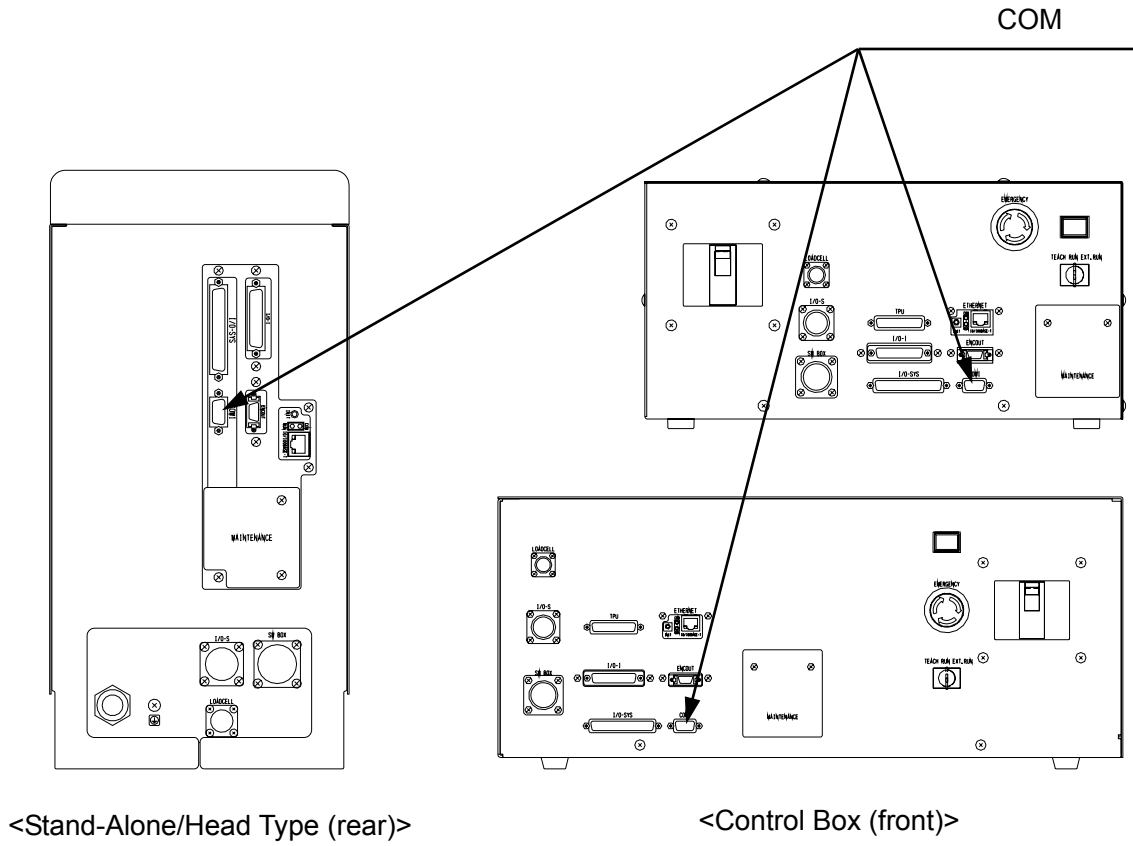

<Pin No.>

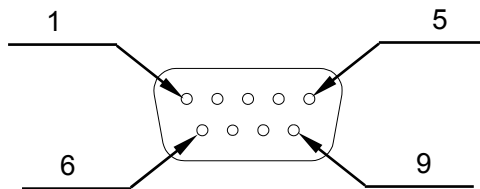

- * On the Electro Press
- * On the control box

7. SWITCH BOX CONNECTOR

7-1 Switch Box Connector

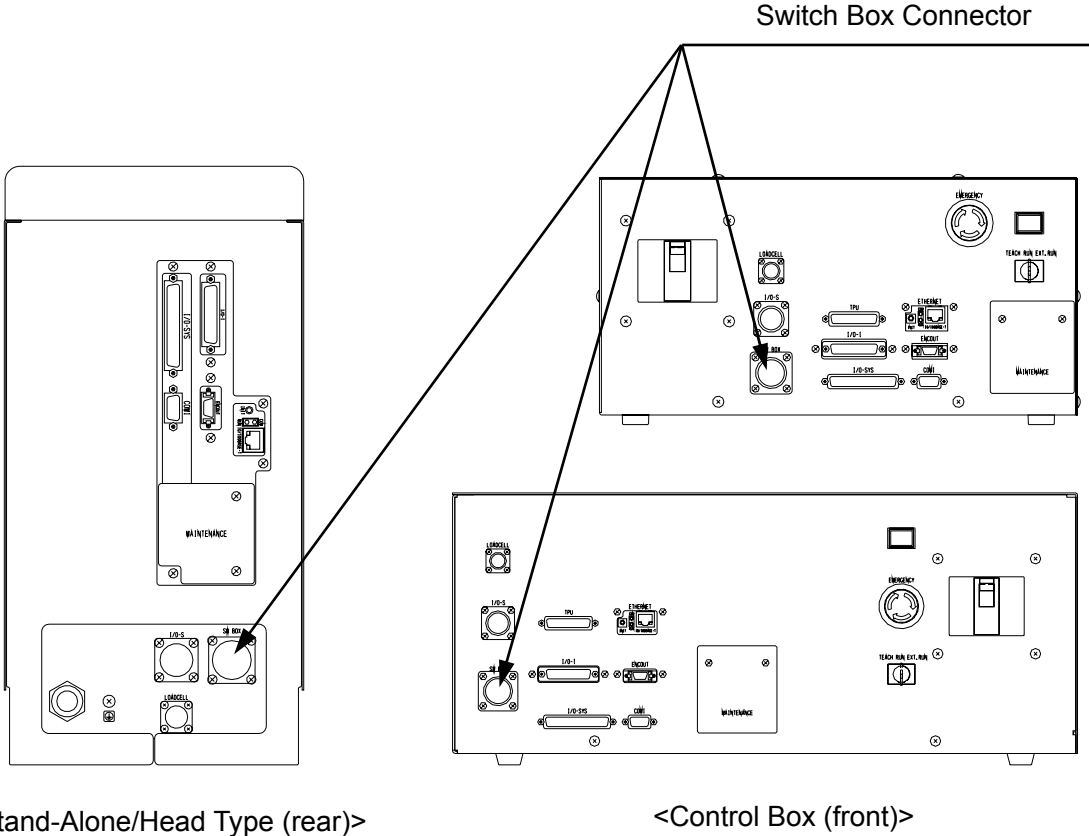

<Pin No.>

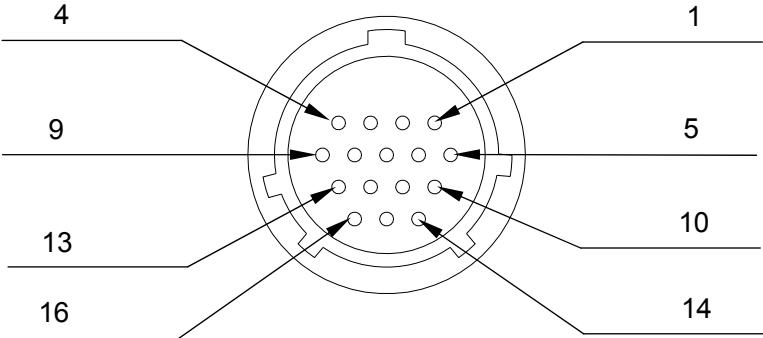

* On the Electro Press (on the control box)

7-2 Switch Box Connector Assignment

PIN No.	Name	Functions
1	SWL	Start Switch (left) Input
2	COM-	GND
3	SWR	Start Switch (right) Input
4	COM-	GND
5	EMG1-1	Emergency Stop 1-1 Input
6	EMG1-2	Emergency Stop 1-2 Input
7	EMG2-1	Emergency Stop 2-1 Input
8	EMG2-2	Emergency Stop 2-2 Input
9	EMG3-1	Emergency Stop 3-1 Input
10	EMG3-2	Emergency Stop 3-2 Input
11	COM+	24V Power Supply
12	INILED	Initialization Switch LED Output (NPN Transistor Output)
13	INI	Initialization Switch Input
14	COM-	GND
15		NC
16		NC

8. TEACHING PENDANT CONNECTOR

8-1 Teaching Pendant Connector

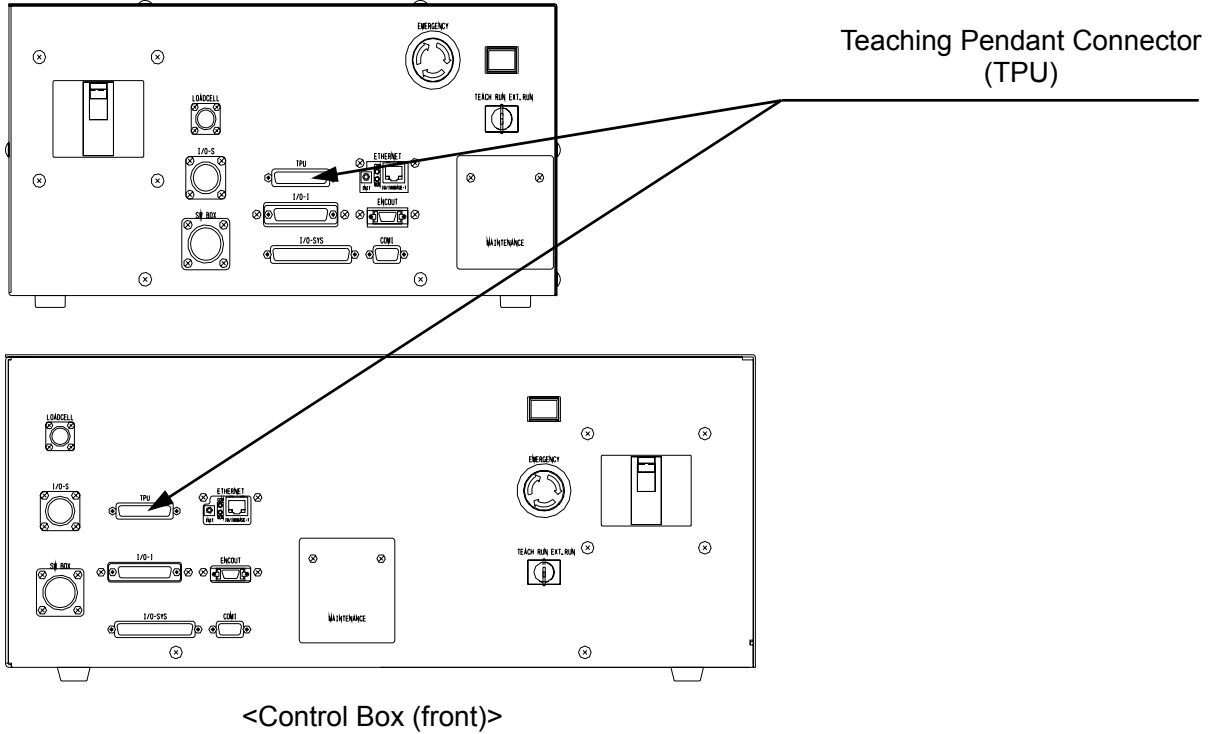

- This connector can be used for the teaching pendant or monitor box. Connect either of them.

<Pin No.>

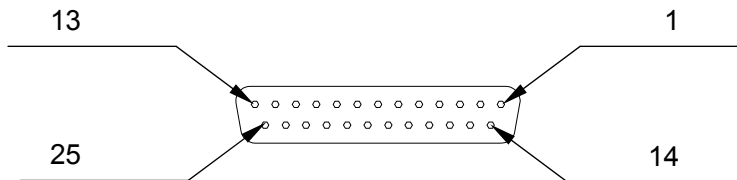

* On the control box

8-2 Pin Assignment of Teaching Pendant Connector

RS422 Interface

Pin No.	Name	Function
1	FG	Frame Ground
2	RD (+)	Receive Data (+)
3	RD (-)	Receive Data (-)
4	SD (+)	Send Data (+)
5	SD (-)	Send Data (-)
6	GND	Communication Signal Ground
7	5V	DC5V
13	GND	DC24V Ground
17	ENSW11	Enable Switch Terminal 1
18	ENSW12	Enable Switch Terminal 2
19	EMGSW11	Emergency Stop Switch Contact Port 1 Terminal 1
20	EMGSW12	Emergency Stop Switch Contact Port 1 Terminal 2
21	EMGSW21	Emergency Stop Switch Contact Port 2 Terminal 1
22	EMGSW22	Emergency Stop Switch Contact Port 2 Terminal 2
23	EMGSW31	Emergency Stop Switch Contact Port 3 Terminal 1
24	EMGSW32	Emergency Stop Switch Contact Port 3 Terminal 2
25	24V	DC24V

8-3 Teaching Pendant Connector Circuit Diagram

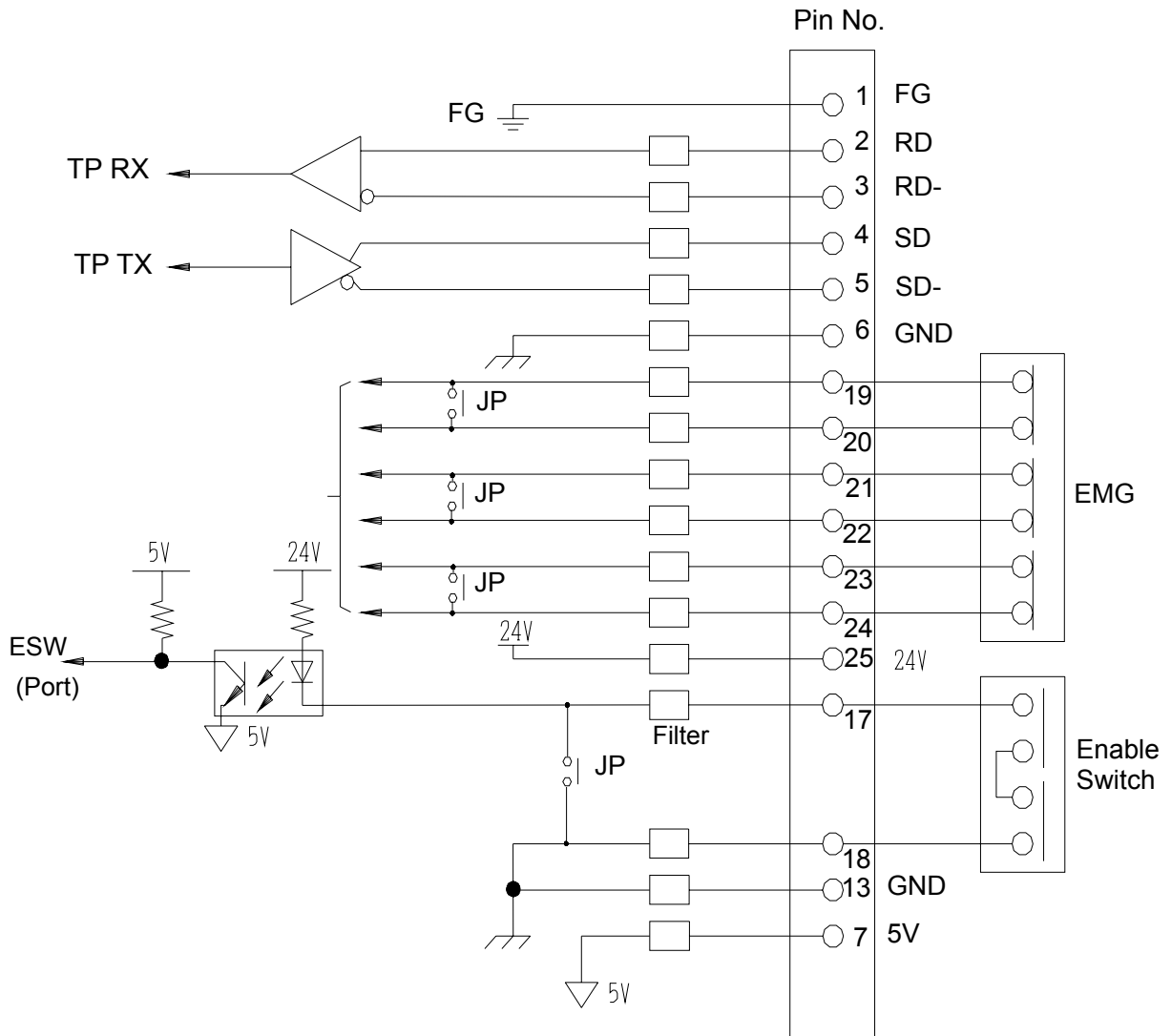

9. LOAD CELL OUTPUT (OPTIONAL)

9-1 Load Cell Output Connector

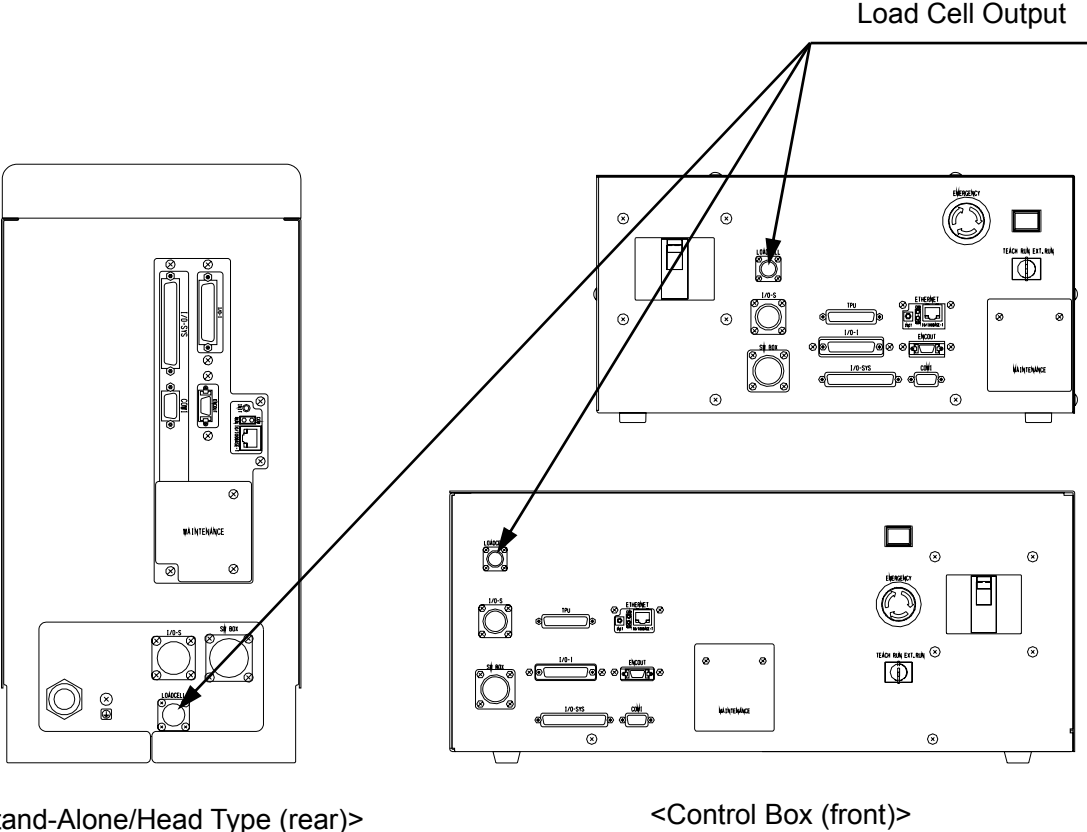

<Pin No.>

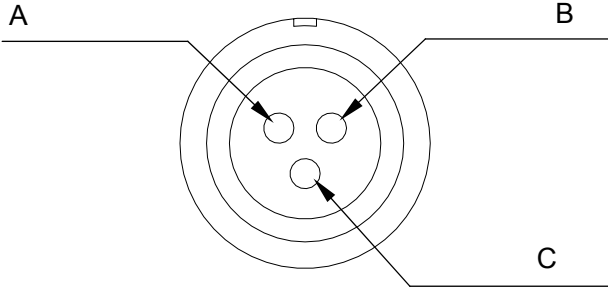

* On the Electro Press (on the control box)

9-2 Pin Assignment of Load Cell Output

Pin No.	Name	Function
A	Output	Analog Output (+)
B	GND	Analog Output (-)
C		NC

The power current is output in the range of DC 4 to 20 mA.

10. ENCODER OUTPUT (OPTIONAL)

10-1 Encoder Output Connector

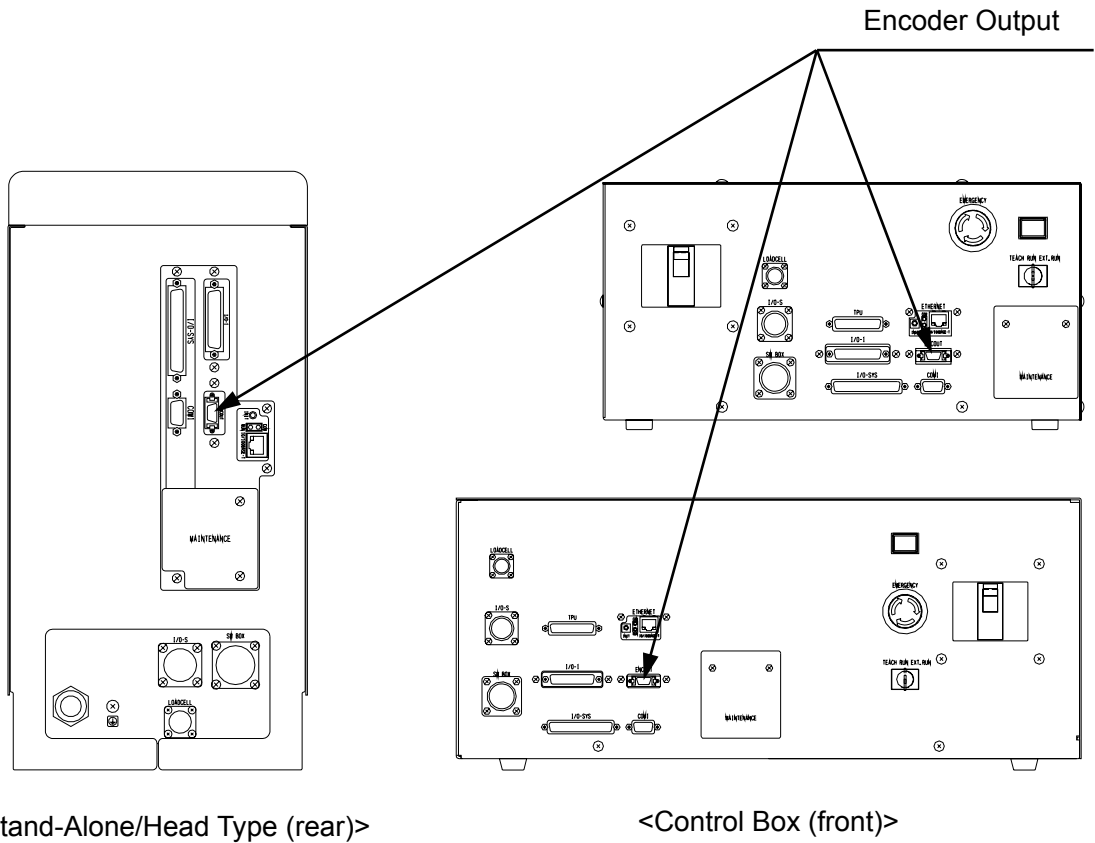

<Pin No.>

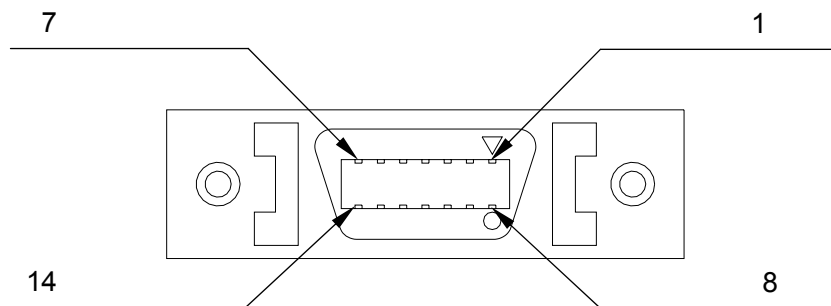

* On the Electro Press
(on the control box)

10-2 Pin Assignment of Encoder Output

Pin No.	Name	Function
1	ENC-A	Encoder A Phase
2	/ENC-A	Encoder/A Phase
3	ENC-B	Encoder B Phase
4	/ENC-B	Encoder/B Phase
5	ENC-C	Encoder C Phase
6	/ENC-C	Encoder/C Phase
7	GND	Signal Ground
8 - 14		NC

Encoder output complies with line driver specification.

Please use a line receiver (AM26C32CNS: T1) or equivalent when you use a encoder.

The encoder outputs pulses from Phases A, B or C.

From Phases A and B, 2000 pulses which correspond to one motor rotation are output. The phase difference is approximately 90 degrees.

From Phase C, 1 pulse which corresponds to one motor rotation is output.

11. MENU LIST

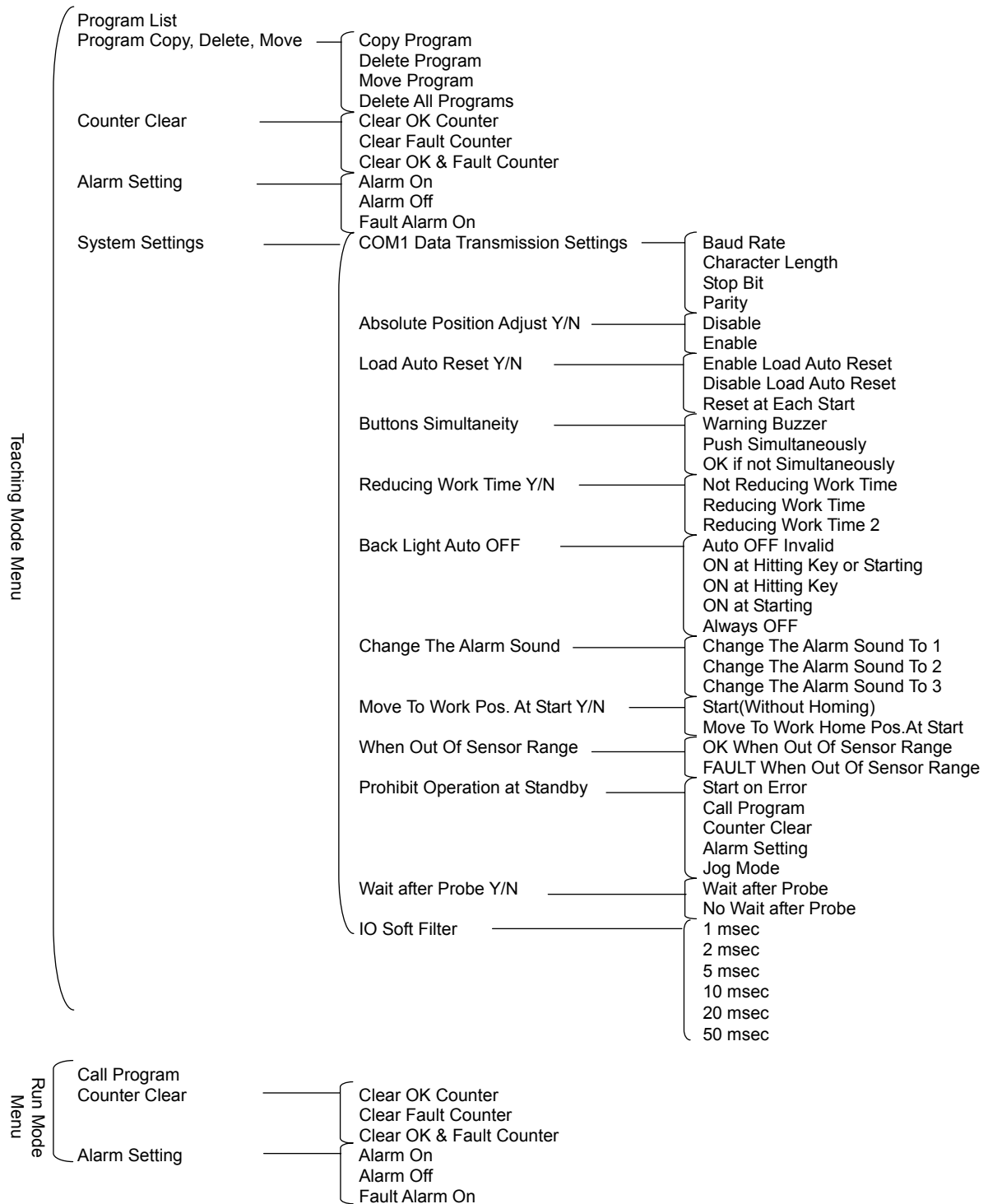

EDIT Menu	{	Add Pressing Section	Const Speed · Set Stop Pos'n
			Const Speed · Set Stop Load
			Const Speed · Set Dist. Mode
			Const Speed · Timed Presser
			Const Speed · Set Stop Pos'n
			Const Speed · Set Dist. Mode
			2 Section · PP
			2 Section · DD
			2 Section · LL
			2 Section · PL
	2 Section · DL		
	2 Section · LP		
	2 Section · LD		
	Delete Pressing Section		
	Change Position Data		

OK/NG Menu	{	Add Sensor Setting	Sensor Pos'n - At Start	
			Sensor Load - Position Range	
			Sensor Load - Distance Range	
			Sampling (Load) - Position Range	
			Sampling (Load) - Distance Range	
			Sensor Speed - In Time Range	
			Sensor Speed - Position Range	
			Sensor Speed - Distance Range	
			Sampling (Speed) - In Time Range	
			Sampling (Speed) - Position Range	
			Sampling (Speed) - Distance Range	
			Sensor Distance - At End	
			Delete Sensor Setting	
			Delete All Sensor Settings	

T.ENV Menu	{	Brightness	
		Unit of Measure	Millimeters [MM][MM/S]
			Inches [IN][IN/S]
		Unit of Load	Newtons [N]
			Kilograms [kg]
			Pounds [lb]
		Display Language	English
			Japanese
			Italian
			Spanish
			French
			German
		Jog Mode Max. Pressure	5500N
			5000N
			4500N
			4000N
			3500N
			3000N
	2500N		
	2000N		
	1500N		
	1000N		
	500N		
Save on Changing Mode	No Limit		
	Valid		
	Invalid		
Key Click	OFF		
	ON-OFF		
	OFF-ON		
	ON		
Back Light on Teaching	ON		
	OFF		

MONITOR Menu

- I/O Test
- Test Run

MODE Menu

- Adjustment
- Version Information
- Setting Information
- Diagnostic Mode
- Mechanical Adjustment Mode

12. SPECIFICATIONS

12-1 Functions

12-1-1 JP/JPH/JPU-104 and 204

Model		JP/JPH/JPU-104	JP/JPH/JPU-204
Press Capacity	Maximum	1000 N (100 kgf)	2000 N (200 kgf)
	Variable range	100 - 1000 N (10 - 100 kgf)	200 - 2000 N (20 - 200 kgf)
	Increment	1 N (0.1 kgf)	1 N (0.1 kgf)
	Min. limit of detection	2 N	4 N
Ram Stroke	Maximum	80 mm	80 mm
	Variable range	0 - 80 mm	0 - 80 mm
	Increment	0.001 mm	0.001 mm
Ram Speed	Approach/Ascending	166 mm/sec	166 mm/sec
	Pressing	0.01 - 35 mm/sec	0.01 - 35 mm/sec
	Increment	0.01 mm/sec	0.01 mm/sec
Holding Time	Maximum	99.9 sec	99.9 sec
	Variable range	0 - 99.9 sec	0 - 99.9 sec
	Increment	0.1 sec	0.1 sec
Repeatability		±0.005 mm	±0.005 mm
Load Control Range		100 - 1000 N (10 - 100 kgf)	200 - 2000 N (20 - 200 kgf)
Stop Mode and Control Function (Quality Control)	Constant Speed · Stop Position mode	<ol style="list-style-type: none"> 1. Load control at stop 2. Load control in sensor position range 3. Sampling (load) control in sensor position range 	
	Constant Speed · Stop Load mode		
	Constant Load · Stop Time mode		
	Constant Load · Stop Position mode (incl. Preset Distance Pressing)		
Screen Display	Unit of measure	N ↔ kgf, Lbf mm ↔ in	
	Display language	English, Japanese, Italian, Spanish, French, German	
Memory Capacity/Life of Program		100 programs/semi-permanent (using flash memory IC)	
External Interface		RS-232C 1ch: for PC control using optional software.	
External I/O Terminals		17 input and 16 output terminals	
Operation and Control Method		AC servomotor, 32 bits CPU	
Ambient Temperature		0-40 °C, 20-90 % humidity (non condensing)	
Power Supply	3-phase	180 - 250V 300W	180 - 250V 300W
	Single-phase		
Size and Weight	Stand-alone type	520W x 567D x 750H (mm)	100 kg
	Head type	282W x 472D x 470H (mm)	80 kg
	Unit type	118W x 415D x 213H (mm)	18 kg
	Control box	398W x 280D x 198H (mm)	13 kg

● The specifications may be changed to improve quality without prior notice.

12-1-2 JP/JPH/JPU-504 and 1004

Model		JP/JPH/JPU-504	JP/JPH/JPU-1004
Press Capacity	Maximum	5000 N (500 kgf)	10 kN (1000 kgf)
	Variable range	500 - 5000 N (50 - 500 kgf)	1 - 10 kN (100 - 1000 kgf)
	Increment	1 N (0.1 kgf)	1 N (0.1 kgf)
	Min. limit of detection	10 N	20 N
Ram Stroke	Maximum	100 mm	100 mm
	Variable range	0 - 100 mm	0 - 100 mm
	Increment	0.001 mm	0.001 mm
Ram Speed	Approach/Ascending	166 mm/sec	116 mm/sec
	Pressing	0.01 - 35 mm/sec	0.01 - 35 mm/sec
	Increment	0.01 mm/sec	0.01 mm/sec
Holding Time	Maximum	99.9 sec	99.9 sec
	Variable range	0 - 99.9 sec	0 - 99.9 sec
	Increment	0.1 sec	0.1 sec
Repeatability		±0.005 mm	±0.005 mm
Load Control Range		500 - 5000 N (50 - 500 kgf)	1 - 10 kN (100 - 1000 kgf)
Stop Mode and Control Function (Quality Control)	Constant Speed · Stop Position mode	<ol style="list-style-type: none"> 1. Load control at stop 2. Load control in sensor position range 3. Sampling (load) control in sensor position range 	
	Constant Speed · Stop Load mode		
	Constant Load · Stop Time mode		
	Constant Load · Stop Position mode (incl. Preset Distance Pressing)		
Screen Display	Unit of measure	N ↔ kgf, Lbf mm ↔ in	
	Display language	English, Japanese, Italian, Spanish, French, German	
Memory Capacity/Life of Program		100 programs/semi-permanent (using flash memory IC)	
External Interface		RS-232C 1ch: for PC control using optional software.	
External I/O Terminals		17 input and 16 output terminals	
Operation and Control Method		AC servomotor, 32 bits CPU	
Ambient Temperature		0-40 °C, 20-90 % humidity (non condensing)	
Power Supply	3-phase	180 - 250V 850W	180 - 250V 850W
	Single-phase		
Size and Weight	Stand-alone type	520W x 580D x 875H (mm)	160 kg
	Head type	280W x 505D x 495H (mm)	100 kg
	Unit type	146W x 495D x 250H (mm)	35 kg
	Control box	398W x 280D x 198H (mm)	13 kg

● The specifications may be changed to improve quality without prior notice.

12-1-3 JP/JPH/JPU-1504

Model		JP/JPH/JPU-1504	
Press Capacity	Maximum	15 kN (1000 kgf)	
	Variable range	1.5 - 15 kN (100 - 1000 kgf)	
	Increment	1 N (0.1 kgf)	
	Min. limit of detection	30 N	
Ram Stroke	Maximum	100 mm	
	Variable range	0 - 100 mm	
	Increment	0.001 mm	
Ram Speed	Approach/Ascending	100 mm/sec	
	Pressing	0.01 - 20 mm/sec	
	Increment	0.01 mm/sec	
Holding Time	Maximum	99.9 sec	
	Variable range	0 - 99.9 sec	
	Increment	0.1 sec	
Repeatability		± 0.05 mm	
Load Control Range		1.5 - 15 kN (150 - 1500 kgf)	
Stop Mode and Control Function (Quality Control)	Constant Speed·Stop Position mode	<ol style="list-style-type: none"> 1. Load control at stop 2. Load control in sensor position range 3. Sampling (load) control in sensor position range 	
	Constant Speed·Stop Load mode		
	Constant Load·Stop Time mode		
	Constant Load·Stop Position mode (incl. Preset Distance Pressing)		
Screen Display	Unit of measure	N ↔ kgf, Lbf mm ↔ in	
	Display language	English, Japanese, Italian, Spanish, French, German	
Memory Capacity/Life of Program		100 programs/semi-permanent (using flash memory IC)	
External Interface		RS-232C 1ch: for PC control using optional software.	
External I/O Terminals		17 input and 16 output terminals	
Operation and Control Method		AC servomotor, 32 bits CPU	
Ambient Temperature		0-40 , 20-90 % humidity (non condensing)	
Power Supply	3-phase	180 – 250V 850W	
	Single-phase		
Size and Weight	Stand-alone type	520W x 580D x 875H (mm)	160 kg
	Head type	280W x 505D x 495H (mm)	100 kg
	Unit type	146W x 497D x 260H (mm)	35 kg
	Control box	398W x 280D x 198H (mm)	13 kg

The specifications may be changed to improve quality without prior notice.

12-1-4 JP/JPH/JPU-3004 and 5004

Model		JP/JPH/JPU-3004	JP/JPH/JPU-5004
Press Capacity	Maximum	30 kN (3000 kgf)	50 kN (5000 kgf)
	Variable range	3 - 30 kN (300 - 3000 kgf)	5 - 50 kN (500 - 5000 kgf)
	Increment	10 N (1 kgf)	10 N (1 kgf)
	Min. limit of detection	60 N	100 N
Ram Stroke	Maximum	200 mm	200 mm
	Variable range	0 - 200 mm	0 - 200 mm
	Increment	0.002 mm	0.002 mm
Ram Speed	Approach/Ascending	300 mm/sec	300 mm/sec
	Pressing	0.01 - 35 mm/sec	0.01 - 35 mm/sec
	Increment	0.01 mm/sec	0.01 mm/sec
Holding Time	Maximum	99.9 sec	99.9 sec
	Variable range	0 - 99.9 sec	0 - 99.9 sec
	Increment	0.1 sec	0.1 sec
Repeatability		±0.05 mm	±0.05 mm
Load Control Range		3 - 30 kN (300 - 3000 kgf)	5 - 50 kN (500 - 5000 kgf)
Stop Mode and Control Function (Quality Control)	Constant Speed · Stop Position mode	<ol style="list-style-type: none"> 1. Load control at stop 2. Load control in sensor position range 3. Sampling (load) control in sensor position range 	
	Constant Speed · Stop Load mode		
	Constant Load · Stop Time mode		
	Constant Load · Stop Position mode (incl. Preset Distance Pressing)		
Screen Display	Unit of measure	N ↔ kgf, Lbf mm ↔ in	
	Display language	English, Japanese, Italian, Spanish, French, German	
Memory Capacity/Life of Program		100 programs/semi-permanent (using flash memory IC)	
External Interface		RS-232C 1ch: for PC control using optional software.	
External I/O Terminals		17 input and 16 output terminals	
Operation and Control Method		AC servomotor, 32 bits CPU	
Ambient Temperature		0-40 °C, 20-90 % humidity (non condensing)	
Power Supply	3-phase	180 - 250V 3kW	180 - 250V 5kW
	Single-phase		
Size and Weight	Stand-alone type	560W x 985D x 1315H (mm)	1050 kg
	Head type	660W x 858D x 765H (mm)	650 kg
	Unit type	220W x 775D x 510H (mm)	160 kg
	Control box	550W x 398D x 230H (mm)	40 kg

● The specifications may be changed to improve quality without prior notice.

12-1-5 JPU-8004

Model		JPU-8004	
Press Capacity	Maximum	80 kN (8000 kgf)	
	Variable range	8 - 80 kN (800 - 8000 kgf)	
	Increment	10 N (1kgf)	
	Min. limit of detection	160 N	
Ram Stroke	Maximum	200 mm	
	Variable range	0 - 200 mm	
	Increment	0.002 mm	
Ram Speed	Approach/Ascending	200 mm/sec	
	Pressing	0.01 - 23 mm/sec	
	Increment	0.01 mm/sec	
Holding Time	Maximum	99.9 sec	
	Variable range	0 - 99.9 sec	
	Increment	0.1 sec	
Repeatability		± 0.05 mm	
Load Control Range		8 - 80 kN (800 - 8000 kgf)	
Stop Mode and Control Function (Quality Control)	Constant Speed·Stop Position mode	<ol style="list-style-type: none"> 1. Load control at stop 2. Load control in sensor position range 3. Sampling (load) control in sensor position range 	
	Constant Speed·Stop Load mode		
	Constant Load·Stop Time mode		
	Constant Load·Stop Position mode (incl. Preset Distance Pressing)		
Screen Display	Unit of measure	N ↔ kgf, Lbf mm ↔ in	
	Display language	English, Japanese, Italian, Spanish, French, German	
Memory Capacity/Life of Program		100 programs/semi-permanent (using flash memory IC)	
External Interface		RS-232C 1ch: for PC control using optional software.	
External I/O Terminals		17 input and 16 output terminals	
Operation and Control Method		AC servomotor, 32 bits CPU	
Ambient Temperature		0-40 , 20-90 % humidity (non condensing)	
Power Supply	3-phase	180 – 250V 5kW	
	Single-phase		
Size and Weight	Stand-alone type	560W x 985D x 1315H (mm)	1050 kg
	Head type	660W x 858D x 765H (mm)	650 kg
	Unit type	220W x 775D x 510H (mm)	160 kg
	Control box	550W x 398D x 230H (mm)	40 kg

The specifications may be changed to improve quality without prior notice.

APPENDIX. GENERAL EXTERNAL I/O TIMING CHART

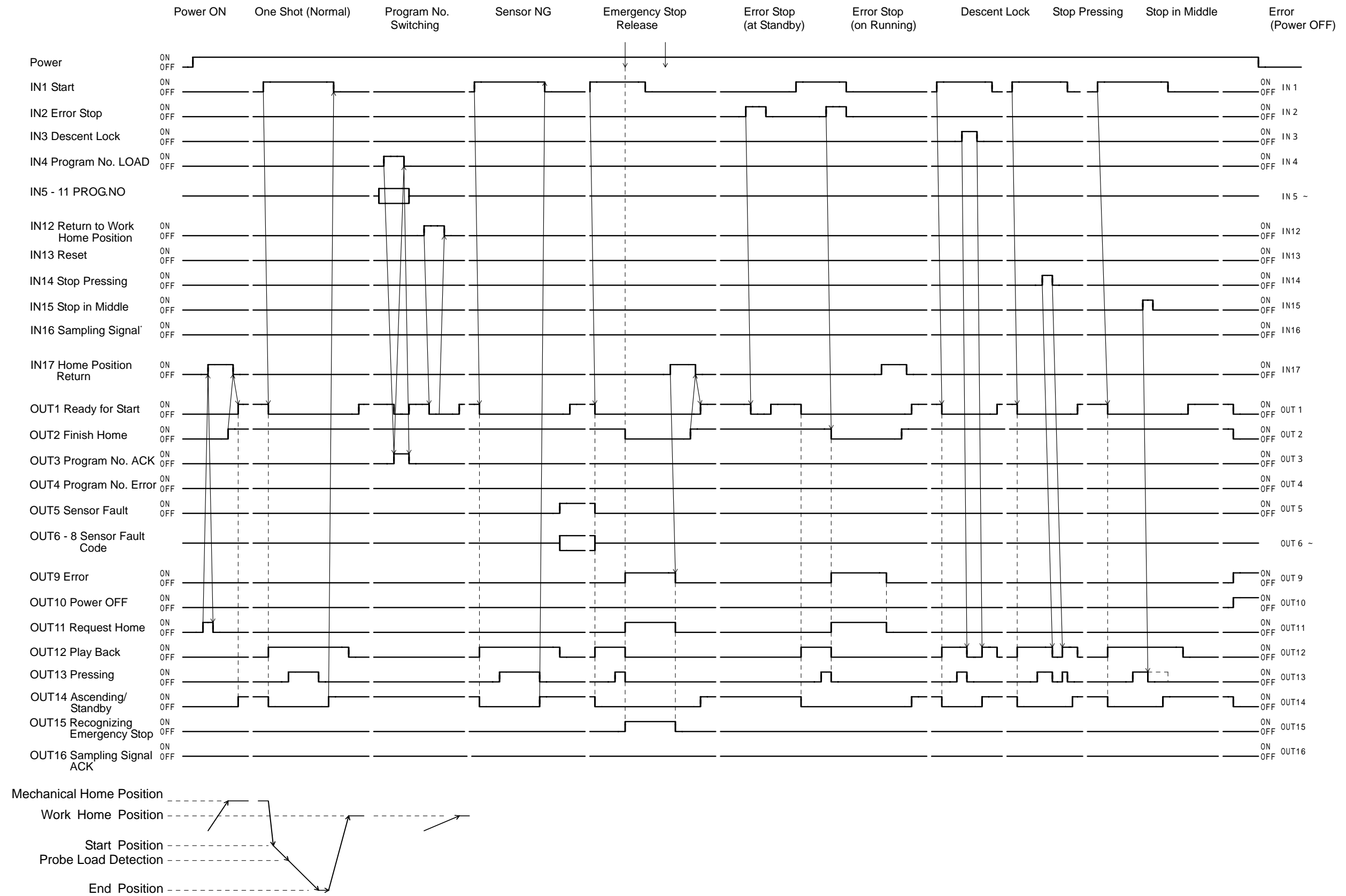

JANOME Sewing Machine Co., Ltd.
Industrial Automation Systems Division

Zip Code: 193-0941

1463 Hazama-cho, Hachioji-shi, Tokyo, Japan

Tel: +81-426-61-6301

Fax: +81-426-61-6302

The specifications of the machine or the contents of this manual may be modified without prior notice to improve its quality.

No part of this manual may be reproduced in any form, including photocopying, reprinting, or translation to another language, without the prior written consent of JANOME.

* The “Electro Press” is a product name of JANOME.

©2004, JANOME Sewing Machine Co., Ltd., All rights reserved.

891806103 as of 08/2005

6 September, 2005